

3 Port Solenoid Valve

Power Consumption
0.1 W
 With Power Saving Circuit

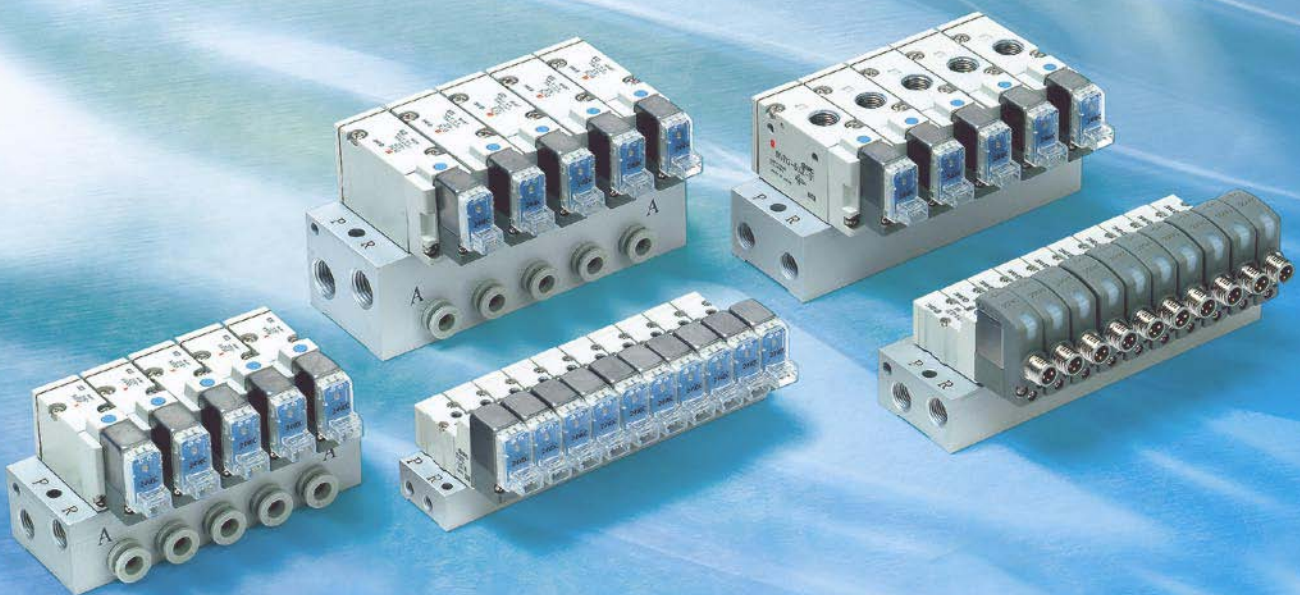

Series SYJ300/500/700



● Improved pilot valve







Pilot valve cover is stronger using stainless steel.
 Mounting thread is also reinforced from size M1.7 to M2.

● Flow Characteristics

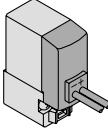
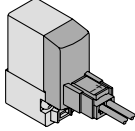
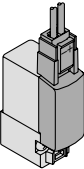
Series	Flow characteristics			
	C [dm ³ /(s·bar)]	b	Cv	Q [l/min(ANR)]
SYJ300	0.36	0.31	0.089	92
SYJ500	1.2	0.41	0.32	329
SYJ700	2.7	0.38	0.72	724

Rubber Seal 3 Port Solenoid Valve Series *SYJ300/500/700*

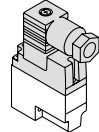
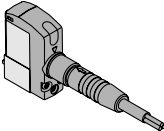
Variations

	Series	Port size	Sonic conductance C [dm ³ /(s·bar)]	Type of actuation	Voltage	Electrical entry	Option	Manual override			
							With light/surge voltage suppressor				
Body ported	SYJ300  P.1	M3	[Effective area 0.9 mm ² { 2→3 } { (A→R) }]	● N.C. ● N.O.	For DC ■ 24 VDC 12 VDC 6 VDC 5 VDC 3 VDC	Grommet  L plug connector  M plug connector 	For DC ■ With surge voltage suppressor ■ With light/surge voltage suppressor	■ Non-locking push type			
	SYJ500  P.15	M5	0.66 { 2→3 } { (A→R) }								
	SYJ700  P.33	1/8	2.5 { 2→3 } { (A→R) }								
Base mounted	SYJ300  P.1	M5	0.36 { 2→3 } { (A→R) }				● N.C. ● N.O.	For AC ■ 100 VAC ^{50/60} Hz 110 VAC ^{50/60} Hz 200 VAC ^{50/60} Hz 220 VAC ^{50/60} Hz	DIN terminal  (SYJ500, 700 only) M8 connector 	For AC ^{Note)} ■ With light/surge voltage suppressor	■ Push-turn locking slotted type ■ Push-turn locking lever type
	SYJ500  P.15	1/8	1.2 { 2→3 } { (A→R) }								
	SYJ700  P.33	1/8, 1/4	2.7 { 2→3 } { (A→R) }								

 Note) All AC voltage models have built-in surge voltage suppressor.

Manifold Variations

Valve series	A port location	P, R ports size	A port size									
			M3	M5	1/8	With one-touch fitting						
						Applicable tubing O.D.						
			ø4	ø6	ø8	N3	N7	N9				
Body ported	SYJ300	Top	M5	Note 1) ●	—	—	—	—	—	—	—	—
		Top	1/8	Note 2) ●	—	—	—	—	—	—	—	—
	SYJ500	Top	1/8	—	●	—	—	—	—	—	—	—
		SYJ700	Top	1/8	—	—	Note 1) ●	—	—	—	—	—
Top	1/4		—	—	●	—	—	—	—	—	—	
Base mounted	SYJ300	Side	M5	Note 1) ●	—	—	—	—	—	—	—	—
		Side	1/8	—	●	—	●	—	—	●	—	—
	SYJ500	Bottom	1/8	—	●	●	—	—	—	—	—	—
		Side		—	●	●	●	●	—	●	●	—
	SYJ700	Bottom	1/8	—	—	Note 1) ●	—	—	—	—	—	—
			1/4	—	—	●	—	—	—	—	—	—
Side		1/4	—	—	●	—	●	●	—	●	●	

Note 1) Only for internal pilot
 Note 2) Only for external pilot

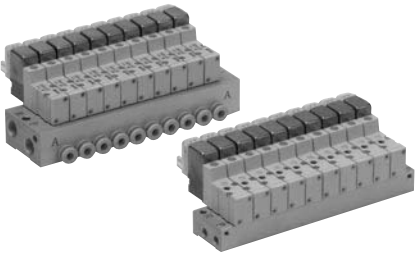

Series SYJ300

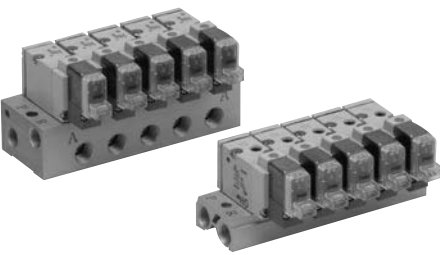

Series SYJ500

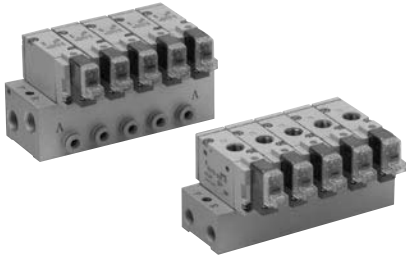

Series SYJ700

Rubber Seal 3 Port Pilot Solenoid Valve Series SYJ300

 Refer to www.smcworld.com for details of products compatible with overseas standards.

Specifications

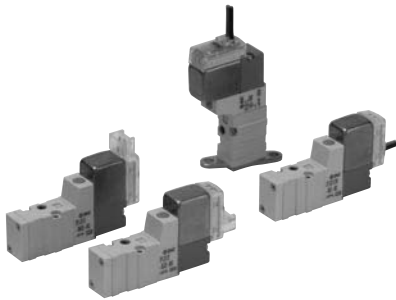

Body ported

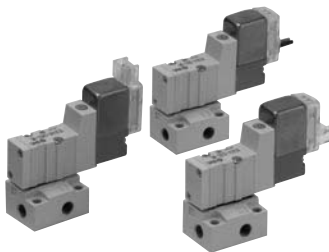

Base mounted

Fluid		Air
Operating pressure range (MPa)	Internal pilot	0.15 to 0.7
Ambient and fluid temperature (°C)		-10 to 50 (No freezing. Refer to back page 2.)
Response time ms (at 0.5 MPa) <small>Note 1)</small>		15 or less
Max. operating frequency (Hz)		10
Manual override (Manual operation)		Non-locking push type, push-turn locking slotted type, push-turn locking lever type
Pilot exhaust method		Individual exhaust for the pilot valve, common exhaust for the pilot and main valve
Lubrication		Not required
Mounting orientation		Unrestricted
Shock/Vibration resistance (m/s²) <small>Note 2)</small>		150/30
Enclosure		Dust proof (* M8 connector conforms to IP65.)



* Based on IEC60529

Note 1) Based on dynamic performance test, JIS B 8374-1981. (Coil temperature: 20°C, at rated voltage, without surge voltage suppressor.)

Note 2) Impact resistance: No malfunction occurred when it is tested in the axial direction and at the right angles to the main valve and armature in both energised and de-energised states every once for each condition. (Value in the initial state)

Vibration resistance: No malfunction occurred in one sweep test between 45 and 2000 Hz. Test was performed to axis and right angle directions of the main valve and armature when pilot signal is ON and OFF. (Value in the initial state)

JIS Symbol

Internal pilot

SYJ31 $\frac{2}{4}$

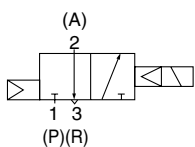

SYJ32 $\frac{2}{4}$

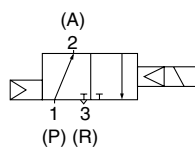

External pilot

SYJ31 $\frac{2}{4}$ R

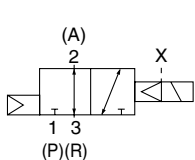

SYJ32 $\frac{2}{4}$ R

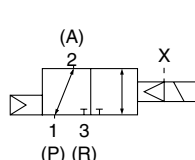

Solenoid Specifications

Electrical entry		Grommet (G), (H), L plug connector (L), M plug connector (M), M8 connector (W)
Coil rated voltage (V)	DC	24, 12, 6, 5, 3
Allowable voltage fluctuation		±10% of rated voltage *
Power consumption (W)	DC	Standard
		With power saving circuit
		0.35 (With light: 0.4)
		0.1 (With light only)
Surge voltage suppressor		Diode (varistor when non-polar types)
Indicator light		LED



* In common between 110 VAC and 115 VAC, and between 220 VAC and 230 VAC.

* For 115 VAC and 230 VAC, the allowable voltage is -15% to +5% of rated voltage.

* S, Z and T type (with power saving circuit) should be used within the following allowable voltage fluctuation range due to a voltage drop caused by the internal circuit.

S and Z type: 24 VDC: -7% to +10%

12 VDC: -4% to +10%

T type: 24 VDC: -8% to +10%

12 VDC: -6% to +10%



Made to Order

(For details, refer to pages 57 through to 59.)

Flow Characteristics/Weight

Valve model		Type of actuation	Port size	Flow characteristics								Effective area (mm ²)	Weight (g) ^{Note)}		
				1→2 (P→A)				2→3 (A→R)					Grommet	L/M plug connector	M8 connector
				C [dm ³ /(s bar)]	b	Cv	Q [l/min(ANR)]*	C [dm ³ /(s bar)]	b	Cv	Q [l/min(ANR)]*				
Body ported	SYJ312	N.C.	M3 x 0.5	—	—	—	—	—	—	—	—	0.9	32	33	37
	SYJ322	N.O.		—	—	—	—	—	—	—	—				
Base mounted (with sub-plate)	SYJ314	N.C.	M5 x 0.8	0.41	0.18	0.086	97	0.35	0.33	0.086	91	—	53 (32)	54 (33)	58 (37)
	SYJ324	N.O.		0.36	0.31	0.089	92	0.36	0.31	0.089	92				

Note) (): Without sub-plate.

* These values have been calculated according to ISO 6358 and represent the flow rate measured in standard conditions at an upstream pressure of 0.6MPa (relative pressure) and a differential pressure of 0.1MPa.

External Pilot

SYJ300R

Pilot valve pressure is supplied separately from the main valve pressure through the use of a separate supply port. It can be used in the vacuum (up to -100 kPa) or low pressure line with 0.15 MPa or less.

Specifications

Applicable model	Base mounted (SYJ314R, SYJ324R)	
Operating pressure range MPa	Main pressure	-100 kPa to 0.7
	External pilot pressure	0.15 to 0.7

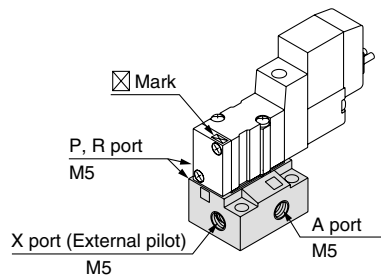

Note 1) For manifold base, refer to page 7.

Note 2) External pilot type body ported valves (SYJ3□2R) can only be used on the manifold.

How to Order

3 port

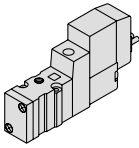

(For manifold type 20, 20R)

Type of actuation

1	Normally closed
2	Normally open

Rated voltage

DC	
5	24 VDC
6	12 VDC
V	6 VDC
S	5 VDC
R	3 VDC

Light/surge voltage suppressor

-	Without light/surge voltage suppressor
S	With surge voltage suppressor
Z	With light/surge voltage suppressor
R	With surge voltage suppressor (Non-polar type)
U	With light/surge voltage suppressor (Non-polar type)

* Power saving circuit is only available in the "Z" type.

Body option

- : Individual pilot exhaust type
- M: Common exhaust for the pilot and main valve
- R: External pilot type*

* SYJ□2R is only for manifold use.

Coil specifications

Nil	Standard
T	With power saving circuit (24, 12 VDC only)

* Power saving circuit is not available in the case of W□ type.

Port size

- : Without sub-plate
- M5: M5 port With sub-plate

(With gasket and screws)

Electrical entry

24, 12, 6, 5, 3 VDC				24, 12, 6, 5, 3 VDC	
Grommet	L plug connector	M plug connector		M8 connector *	
G: Lead wire length 300 mm	L: With lead wire (Length 300 mm)	M: With lead wire (Length 300 mm)	MN: Without lead wire	WO: Without connector cable	
H: Lead wire length 600 mm	LN: Without lead wire	LO: Without connector	MO: Without connector	W□: With connector cable (Note 1)	

* LN, MN type: with 2 sockets.
 * For connector cable of M8 connector, refer to back page 9.
 * Connector M8 type "WA" conforming to IEC 60947-5-2 standard, is also available. For details, see page 58.
 Note 1) Enter the cable length symbols in □. Please be sure to fill in the blank referring to back page 10.

Manual override

- : Non-locking push type
- D: Push-turn locking slotted type
- E: Push-turn locking lever type

Body ported SYJ3 1 2 □ □ 5 M □ □ M3 □ - Q

Base mounted SYJ3 1 4 □ □ 5 M □ □ □ - Q

Body option

- : Without bracket
- F: With bracket

* Bracket is mounted.
 * Brackets cannot be retrofitted.
 * External pilot type is not available.

Note) When placing an order for body ported solenoid valve as a single unit, mounting bolt for manifold and gasket are not attached. Order them separately, if necessary. (For details, refer to page 8.)

Construction

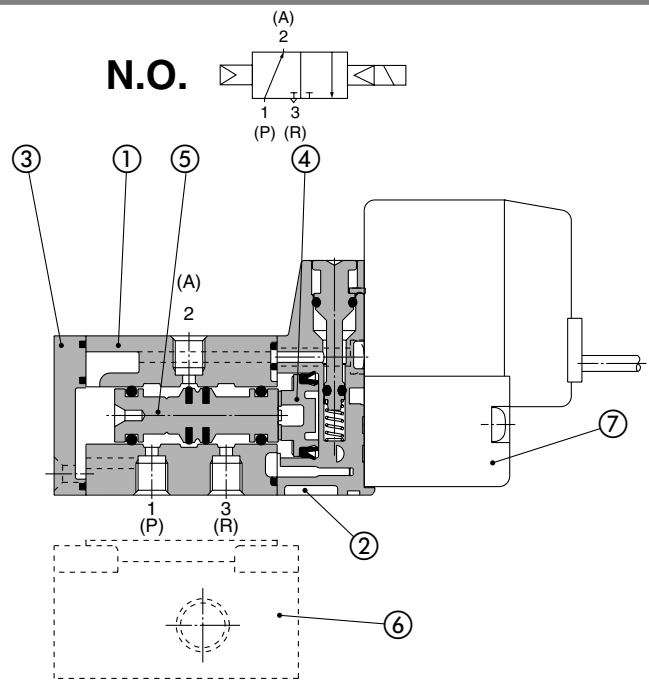
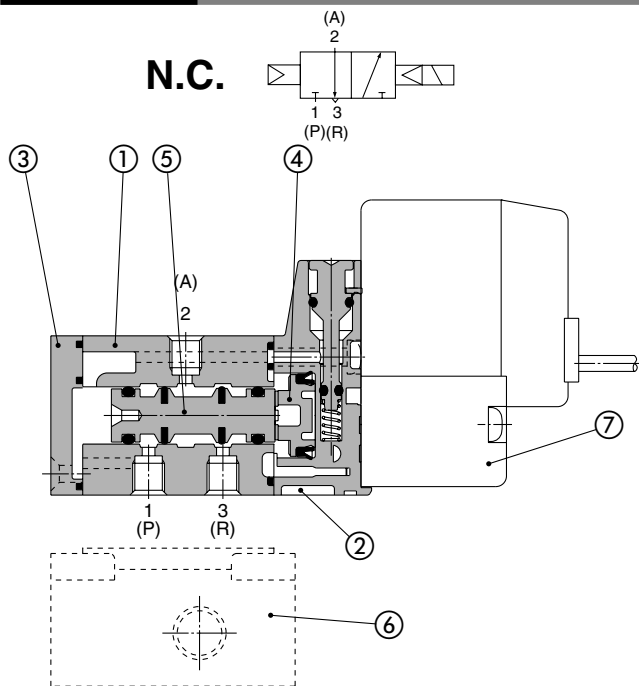

Component Parts

No.	Description	Material	Note
1	Body	Zinc die-casted	White
2	Piston plate	Resin	White
3	End cover	Resin	White
4	Piston	Resin	—
5	Spool valve assembly	Aluminum, H-NBR	—

Replacement Parts

No.	Description	No.	Note
6	Sub-plate	SYJ300-9-1-Q	Zinc die-casted
7	Pilot valve	V111(T)-□□□□	

How to Order Pilot Valve Assembly

V111 □ — 5 G □

Coil specifications

-	Standard
T	With power saving circuit (24, 12 VDC only)

* Power saving circuit is not available in the case of W□ type.

Rated voltage

5	24 VDC
6	12 VDC
V	6 VDC
S	5 VDC
R	3 VDC

Light/surge voltage suppressor

-	Without light/surge voltage suppressor
S	With surge voltage suppressor
Z	With light/surge voltage suppressor
R	With surge voltage suppressor (Non-polar type)
U	With light/surge voltage suppressor (Non-polar type)

* Power saving circuit is only available in the "Z" type.

Electrical entry

G	Grommet, 300 mm lead wire
H	Grommet, 600 mm lead wire
L	L plug connector
LN	Without lead wire
LO	Without connector
M	M plug connector
MN	Without lead wire
MO	Without connector
WO	M8 connector
W□	Without connector cable
W□	With connector cable <small>Note 1)</small>

Note 1) Enter the cable length symbols in □. Please be sure to fill in the blank referring to back page 10.

* For connector cable of M8 connector, refer to back page 9.

How to Order Connector Assembly for L/M Plug Connector

For DC: SY100-30-4A-□

Without lead wire: (with connector and 2 of sockets only) SY100-30-A

Lead wire length

-	300 mm
6	600 mm
10	1000 mm
15	1500 mm
20	2000 mm
25	2500 mm
30	3000 mm
50	5000 mm

How to Order M8 Connector Cable

V100-49-1-□

Cable length

1	300 mm
2	500 mm
3	1000 mm
4	2000 mm
7	5000 mm

Series SYJ300

Body Ported

Grommet (G), (H): SYJ3□2-□_G□□-M3-Q

With bracket:

SYJ3□2-□_H□□-M3-F-Q

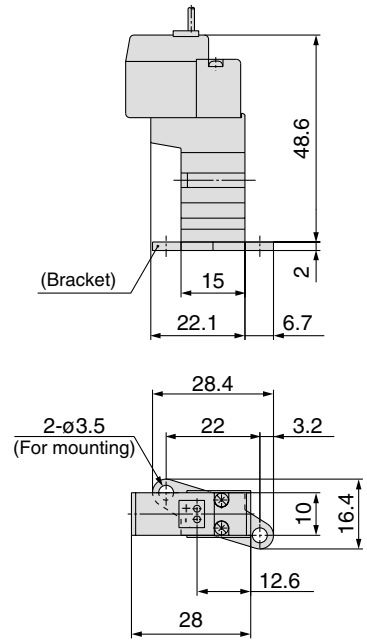
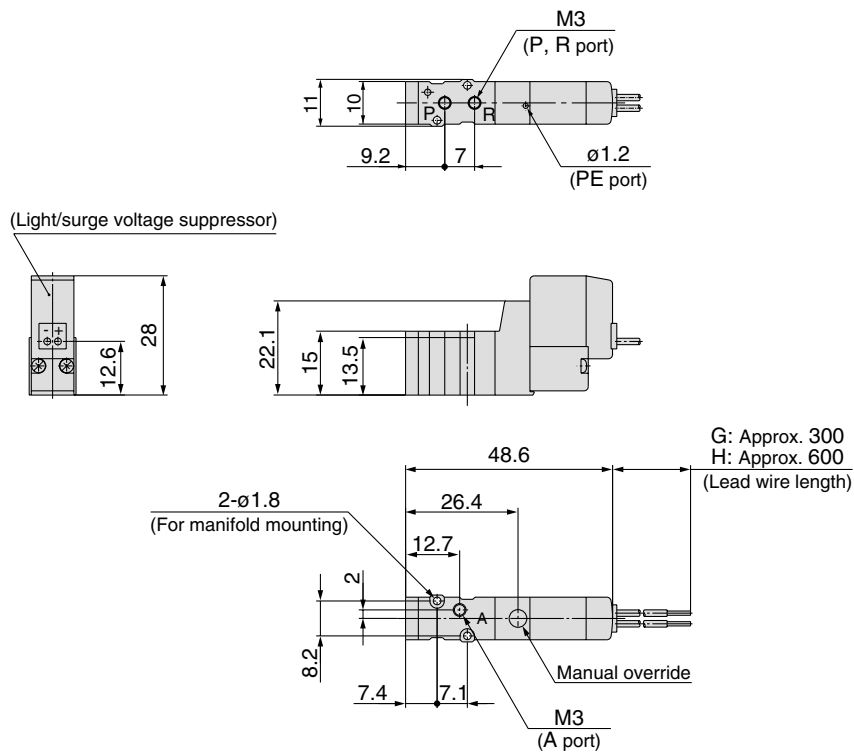

L plug connector (L):
SYJ3□2-□L□□-M3-Q

M plug connector (M):
SYJ3□2-□M□□-M3-Q

M8 connector (WO):
SYJ3□2-□WO□□-M3-Q

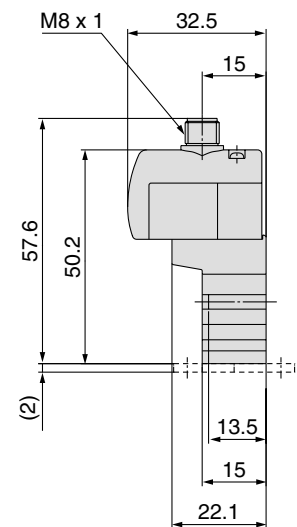
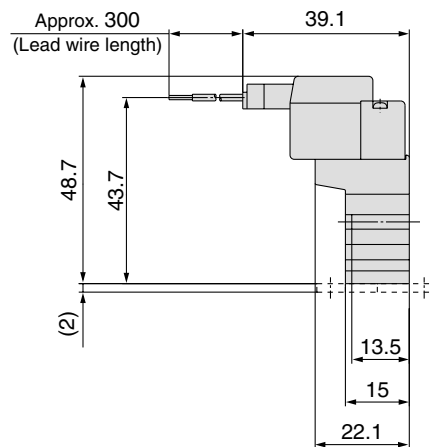
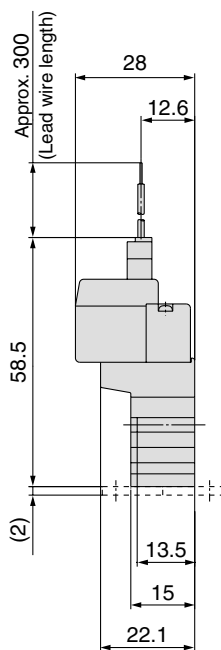

* Refer to back page 10 for dimensions with connector cable.

Base Mounted (With Sub-plate)

Grommet (G), (H): SYJ3□4-□^G□□-M5-Q

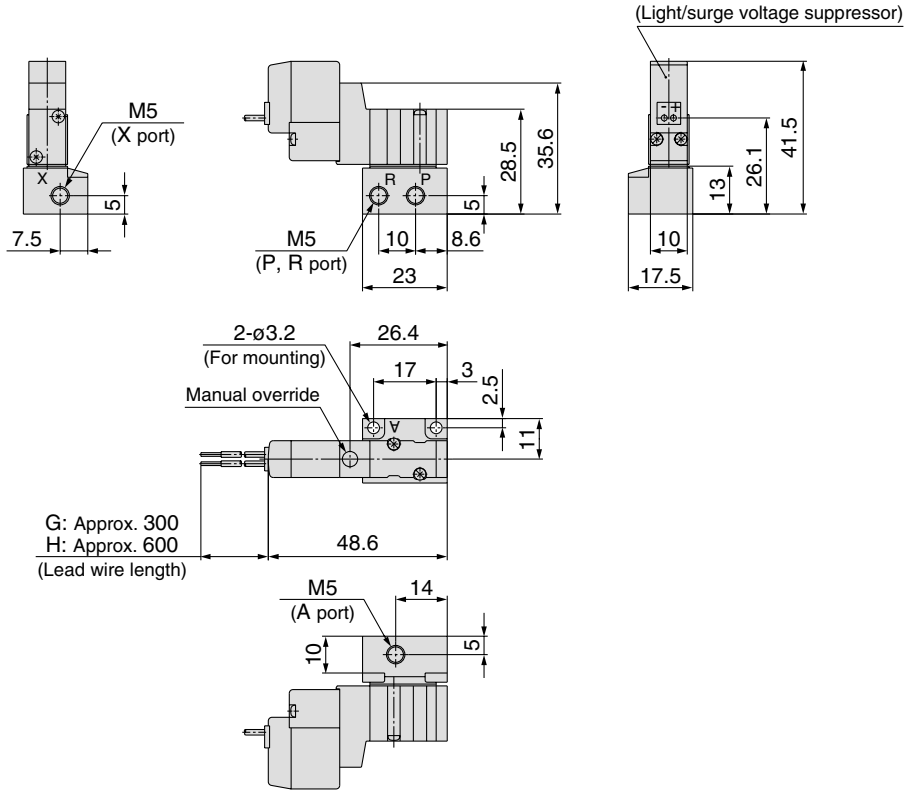

L plug connector (L):
SYJ3□4-□L□□-M5-Q

M plug connector (M):
SYJ3□4-□M□□-M5-Q

M8 connector (WO):
SYJ3□4-□WO□□-M5-Q

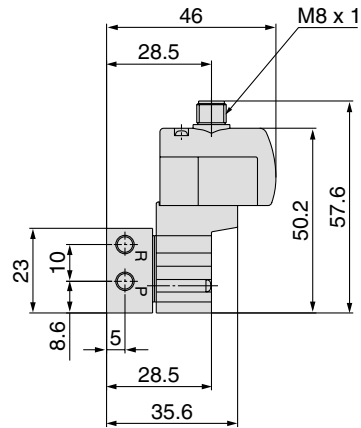
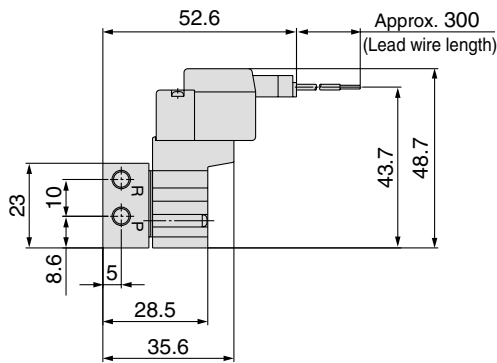
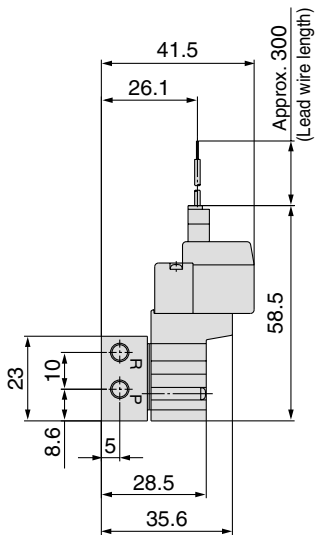

* Refer to back page 10 for dimensions with connector cable.

Series SYJ300 Manifold Specifications

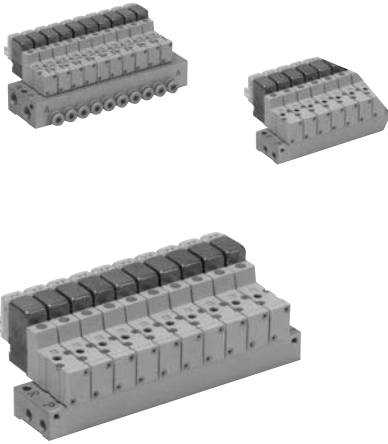

Manifold Specifications

Model	For internal pilot	Type 20	Type 41, S41	Type 42, S42
	For external pilot	Type 20R	—	Type 42R, S42R
Manifold type	Single base/B mount			
P (SUP), R (EXH)	Common SUP/Common EXH			
Valve stations	2 to 20 stations			
A port Porting specifications	Location	Valve	Base	
	Direction	Top	Side	
Port size	P, R port	M5	M5	1/8
		1/8		
	A port	M3	M3	M5 C4 (One-touch fitting ø4)
	X port ^{Note)}	M5	—	M5

Note) Only for external pilot

Flow Characteristics

Manifold			Port size		Flow characteristics								Effective area (mm ²)
					1→2 (P→A)				2→3 (A→R)				
1(P), 3(R) Port	2(A) Port		C [dm ³ /(s bar)]	b	Cv	Q[l/min(ANR)]*	C [dm ³ /(s bar)]	b	Cv	Q[l/min(ANR)]*			
Body ported for internal pilot	Type SS3YJ3-20	SYJ3□2	M5	M3	—	—	—	—	—	—	—	—	0.9
Base mounted for internal pilot	Type SS3YJ3-41 S41	SYJ3□4	M5	M3	—	—	—	—	—	—	—	—	1.5
	Type SS3YJ3-42-M5	SYJ3□4	1/8	M5	0.31	0.17	0.075	73	0.32	0.11	0.072	73	—
	Type SS3YJ3-42-C4			C4	0.33	0.36	0.086	87	0.33	0.2	0.082	79	—
	Type SS3YJ3-S42-M5	SYJ3□4	1/8	M5	0.32	0.3	0.079	81	0.33	0.35	0.086	87	—
Type SS3YJ3-S42-C4	C4			0.35	0.17	0.082	82	0.35	0.26	0.086	87	—	
Body ported for external pilot	Type SS3YJ3-20R	SYJ3□2R	1/8	M3	—	—	—	—	—	—	—	—	0.9
Base mounted for external pilot	Type SS3YJ3-42R-M5	SYJ3□4R	1/8	M5	0.31	0.17	0.075	73	0.32	0.11	0.072	73	—
	Type SS3YJ3-42R-C4			C4	0.33	0.36	0.086	87	0.33	0.20	0.082	79	—
	Type SS3YJ3-S42R-M5	SYJ3□4R	1/8	M5	0.32	0.30	0.079	81	0.33	0.35	0.086	87	—
	Type SS3YJ3-S42R-C4			C4	0.35	0.17	0.082	82	0.35	0.26	0.086	87	—

Note) Value at manifold base mounted, 2 position single acting.
* These values have been calculated according to ISO 6358 and represent the flow rate measured in standard conditions at an upstream pressure of 0.6MPa (relative pressure) and a differential pressure of 0.1MPa.

How to Order Manifold (Example)

Instruct by specifying the valves and blanking plate assembly to be mounted on the manifold along with the manifold base model no.

(Example)

SS3YJ3-20-03-Q.....1 set (manifold base) SS3YJ3-42R-03-C4-Q.....1 set (manifold base)
*SYJ312-5LZ-M3-Q.....2 sets (valve) SYJ314R-5G-Q.....2 sets (valve)
*SYJ300-10-1A-Q.....1 set (blanking plate assembly) SYJ300-10-2A-Q.....1 set (blanking plate assembly)

↳ The asterisk denotes the symbol for assembly. Prefix it to the part nos. of the solenoid valve, etc.

Combinations of Solenoid Valve, Manifold Gasket and Manifold Base

Body ported (Type SYJ3□2(R)-Q)

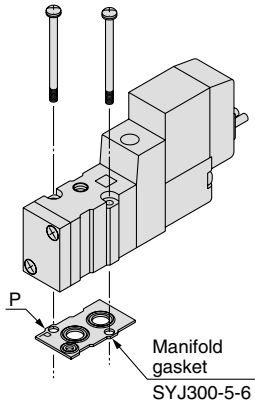

Applicable base
SS3YJ3-20-Q } Manifold
SS3YJ3-20R-Q } base

Base mounted (Type SYJ3□4(R)-Q)

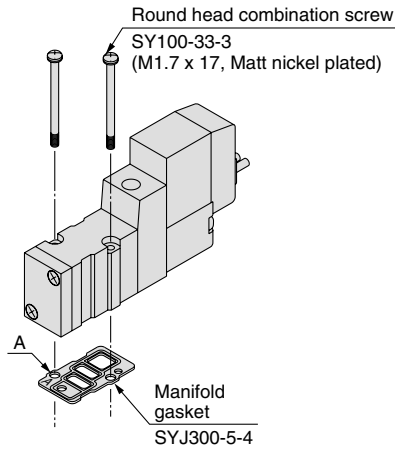

Applicable base
Sub-plate
SS3YJ3-41-Q }
SS3YJ3-S41-Q } Manifold
SS3YJ3-42-Q } base
SS3YJ3-S42-Q }
SS3YJ3-42R-Q }
SS3YJ3-S42R-Q }

Blanking Plate Assembly

Model no.: SYJ300-10-1A-Q

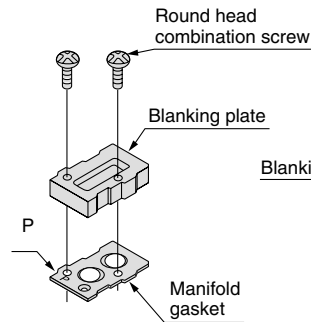

Applicable base
SS3YJ3-20-Q } Manifold
SS3YJ3-20R-Q } base

Model no.: SYJ300-10-2A-Q

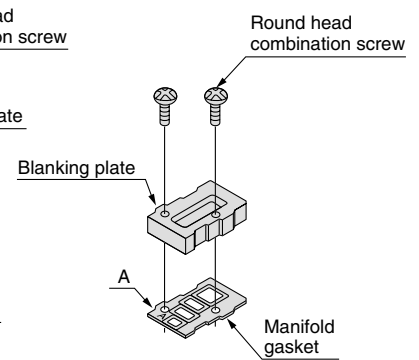

Applicable base
Sub-plate
SS3YJ3-41-Q }
SS3YJ3-S41-Q } Manifold
SS3YJ3-42-Q } base
SS3YJ3-S42-Q }
SS3YJ3-42R-Q }
SS3YJ3-S42R-Q }

⚠ Caution

Mounting screw tightening torques

M1.7: 0.12 N·m

Use caution to the assembly orientation for solenoid valves, gasket, and optional parts.

Series SYJ300

Manifold for Internal Pilot Type

Type 20

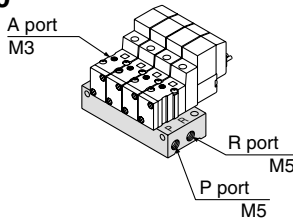

How to Order

SS3YJ3-20-05-□-Q

Stations	
02	2 stations
:	:
20	20 stations

Bracket	
-	Without bracket
F	With bracket

Applicable solenoid valve
 SYJ312-□□□□-M3-Q
 SYJ312M-□□□□-M3-Q
 SYJ322-□□□□-M3-Q
 SYJ322M-□□□□-M3-Q

Applicable blanking plate assembly
 SYJ300-10-1A-Q

Note) For more than 10 stations, supply air to both sides of P port and exhaust air from both sides of R port.

Type 41

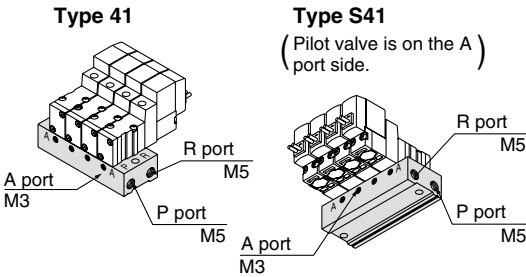

How to Order

SS3YJ3-□-41-05-M3-Q

Valve mounting direction

-	Pilot valve is opposite the A port side.
S	Pilot valve is on the A port side.

Stations

02	2 stations
:	:
20	20 stations

Applicable solenoid valve
 SYJ314-□□□□-Q
 SYJ314M-□□□□-Q
 SYJ324-□□□□-Q
 SYJ324M-□□□□-Q

Applicable blanking plate assembly
 SYJ300-10-2A-Q

Note) For more than 10 stations, supply air to both sides of P port and exhaust air from both sides of R port.

Type 42

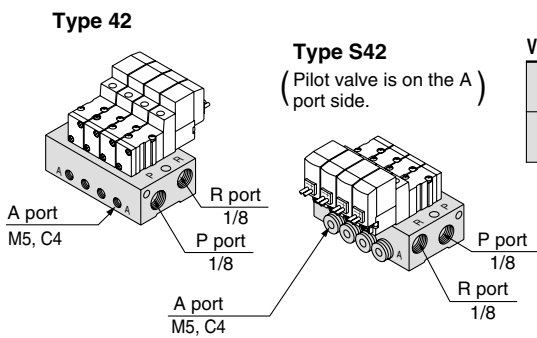

How to Order

SS3YJ3-□-42-05-M5-□-Q

Valve mounting direction

Nil	Pilot valve is opposite the A port side.
S	Pilot valve is on the A port side.

Stations

02	2 stations
:	:
20	20 stations

A port size

M5	M5
C4	ø4 one-touch fitting
N3	ø5/32" one-touch fitting

Applicable solenoid valve
 SYJ314-□□□□
 SYJ314M-□□□□
 SYJ324-□□□□
 SYJ324M-□□□□

Applicable blanking plate assembly
 SYJ300-10-2A

P, R port thread type

-	Rc
F	G
N	NPT
T	NPTF

Note) For more than 8 stations, supply/exhaust air to/from both sides of P port and R port.

Manifold for External Pilot Type

Pilot valve pressure is supplied separately from the main valve pressure through the use of a separate supply port. It can be used in the vacuum (up to -100 kPa) or low pressure line with 0.15 MPa or less.

Type 20R

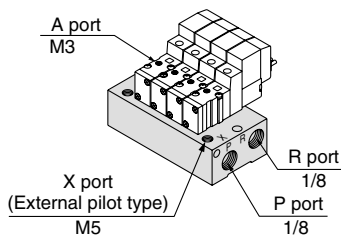

How to Order

SS3YJ3-20R-05-□-Q

Stations	
02	2 stations
:	:
20	20 stations

P, R port thread type

-	Rc
00F	G
00N	NPT
00T	NPTF

Applicable solenoid valve
 SYJ312R-□□□□-M3-Q
 SYJ322R-□□□□-M3-Q

Applicable blanking plate assembly
 SYJ300-10-1A-Q

Note) For more than 10 stations, supply/exhaust air to/from both sides of P port and R port.

Type 42R

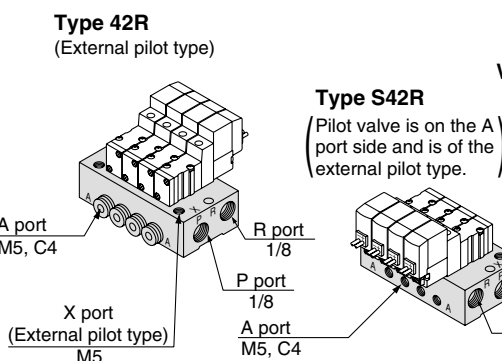

How to Order

SS3YJ3-□-42R-05-M5-□-Q

Valve mounting direction

-	Pilot valve is opposite the A port side.
S	Pilot valve is on the A port side.

Stations

02	2 stations
:	:
20	20 stations

A port size

M5	M5 x 0.8
C4	ø4 one-touch fitting
N3	ø5/32" one-touch fitting

Applicable solenoid valve
 SYJ314R-□□□□-Q
 SYJ324R-□□□□-Q

Applicable blanking plate assembly
 SYJ300-10-2A-Q

P, R port thread type

-	Rc
F	G
N	NPT
T	NPTF

Note) For more than 8 stations, supply/exhaust air to/from both sides of P port and R port.

Type 20 Manifold: Top Ported/SS3YJ3-20- Stations -00□ (-F)-Q

Grommet (G)

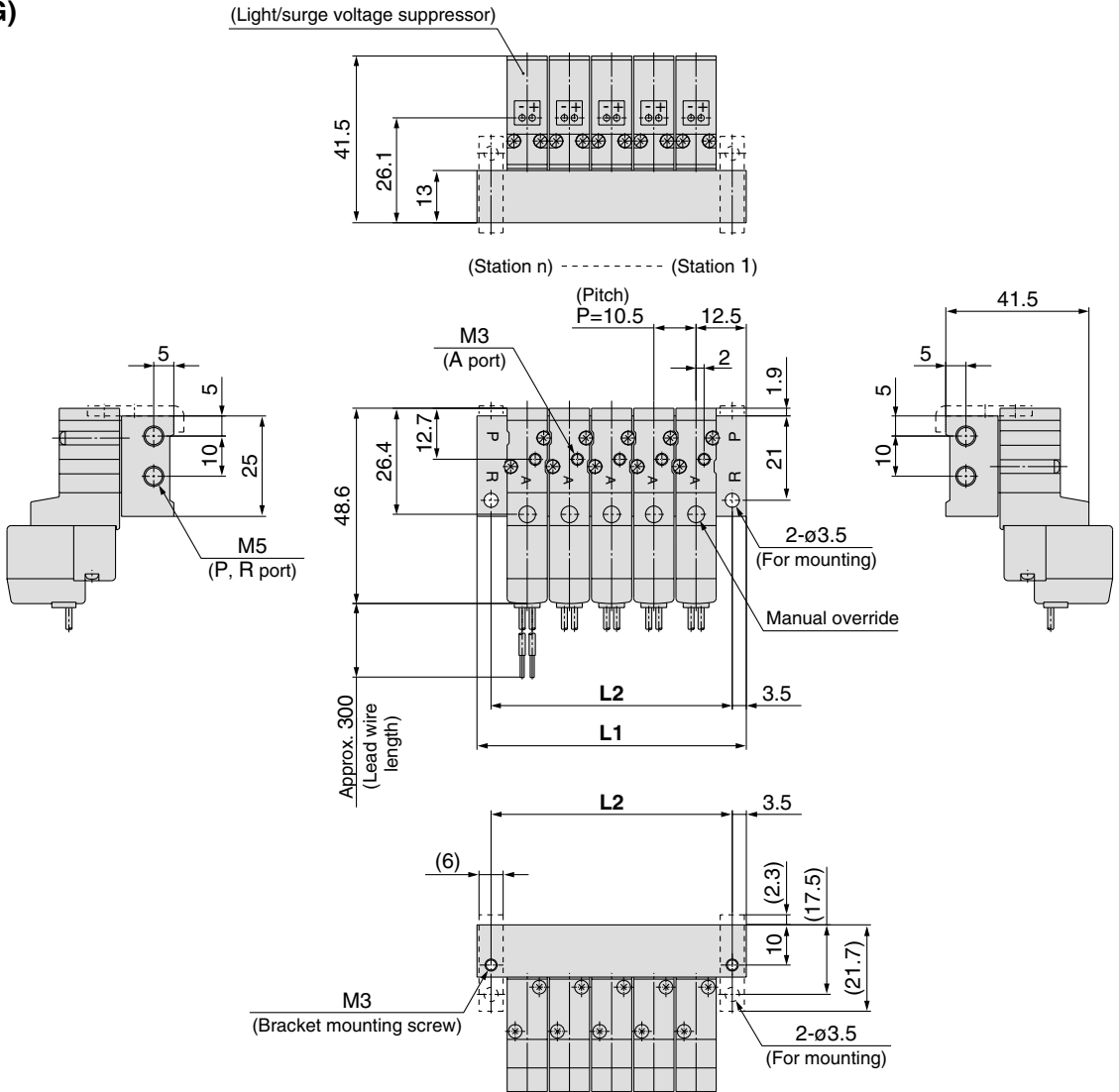

L plug connector (L)

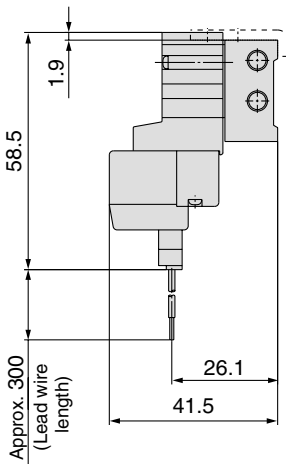

M plug connector (M)

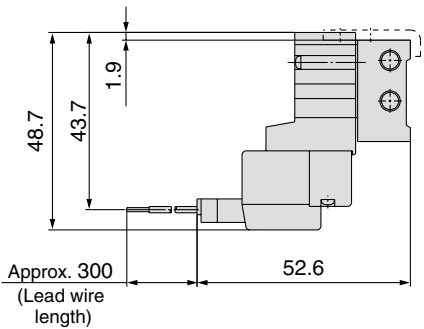

M8 connector (WO)

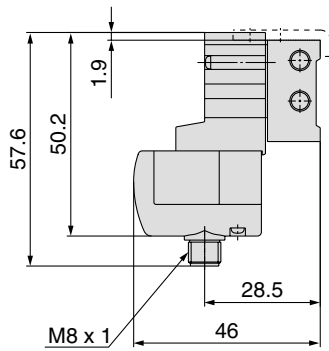

* Refer to back page 10 for dimensions with connector cable.

Station n	2	3	4	5	6	7	8	9	10	11	12	13	14	15	16	17	18	19	20
L1	35.5	46	56.5	67	77.5	88	98.5	109	119.5	130	140.5	151	161.5	172	182.5	193	203.5	214	224.5
L2	28.5	39	49.5	60	70.5	81	91.5	102	112.5	123	133.5	144	154.5	165	175.5	186	196.5	207	217.5

Series SYJ300

Type 41 Manifold: Side Ported/SS3YJ3-41- Stations -M3-Q

Grommet (G)

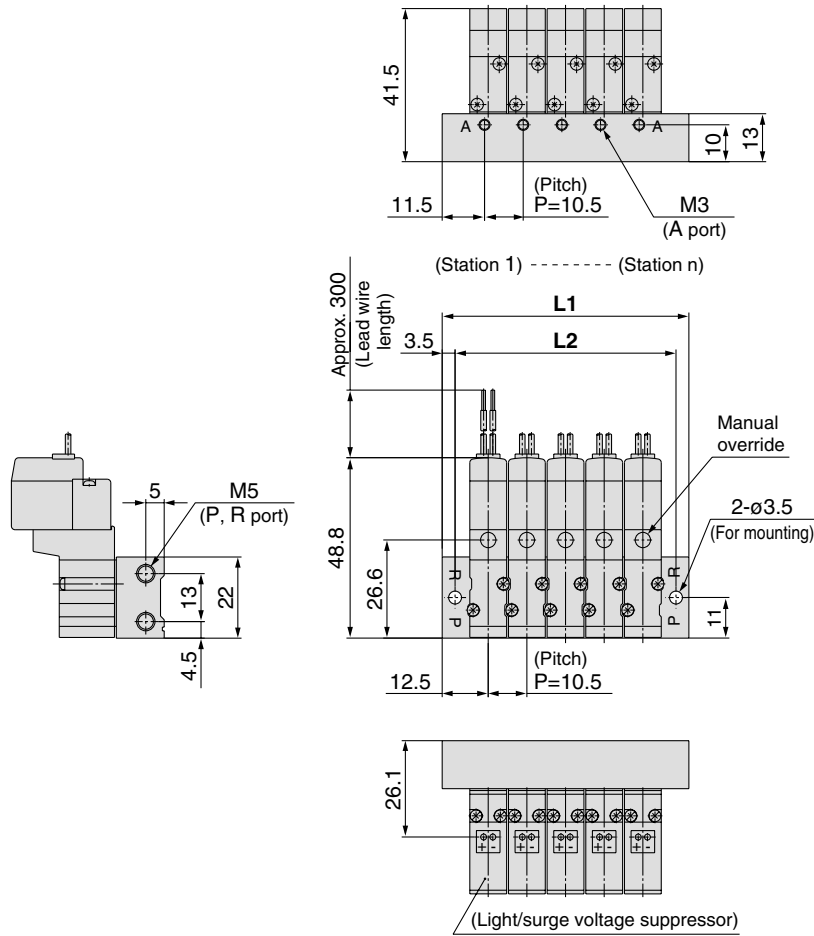

Type 41 Manifold: Side Ported

(Pilot valve is on the A port side) /

SS3YJ3-S41- Stations -M3-Q

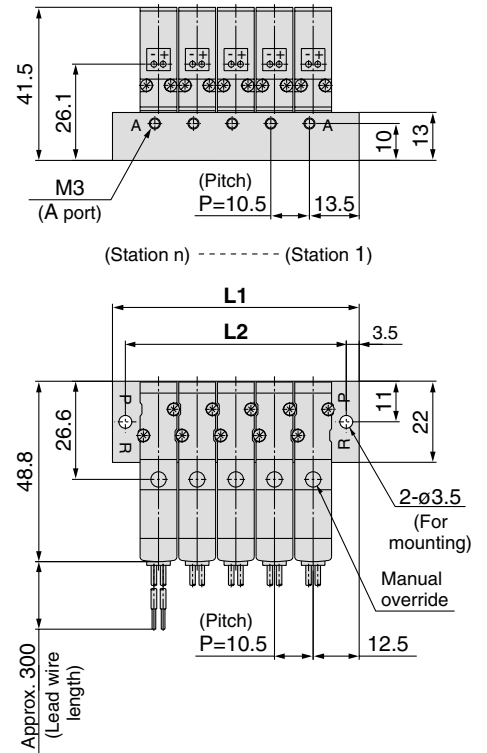

L plug connector (L)

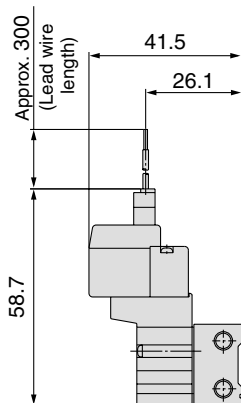

M plug connector (M)

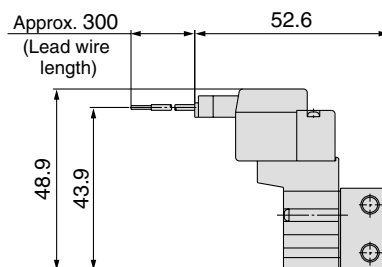

M8 connector (WO)

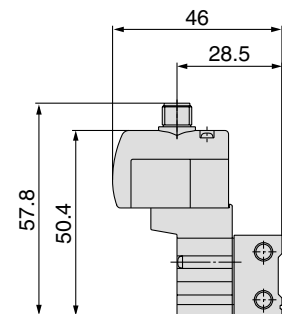

* Refer to back page 10 for dimensions with connector cable.

Station n	Station 2	3	4	5	6	7	8	9	10	11	12	13	14	15	16	17	18	19	Station 20
L1	35.5	46	56.5	67	77.5	88	98.5	109	119.5	130	140.5	151	161.5	172	182.5	193	203.5	214	224.5
L2	28.5	39	49.5	60	70.5	81	91.5	102	112.5	123	133.5	144	154.5	165	175.5	186	196.5	207	217.5

Type 42 Manifold: Side Ported/SS3YJ3-42- Stations -M5, C4 N3 □-Q

Grommet (G)
For M5

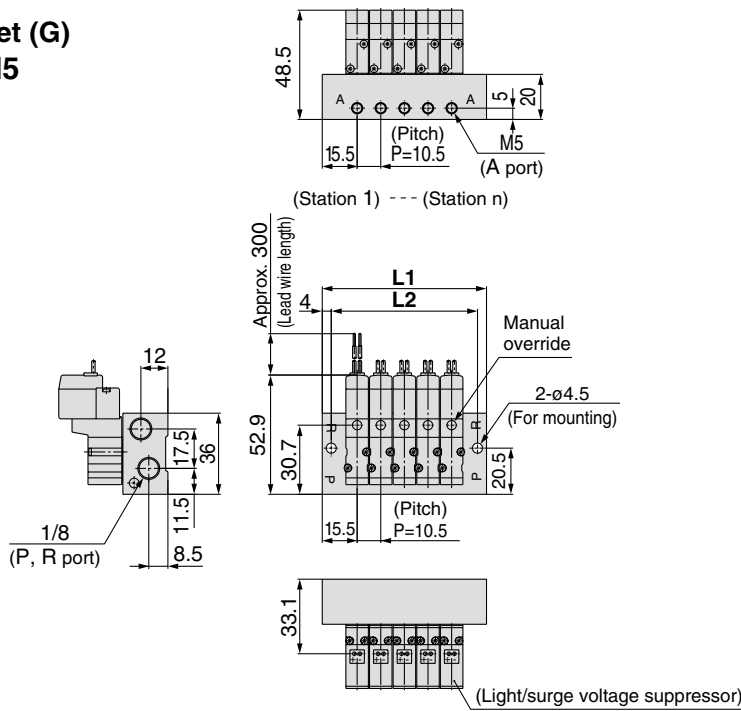

For C4 N3 □ (Built-in one-touch fitting)

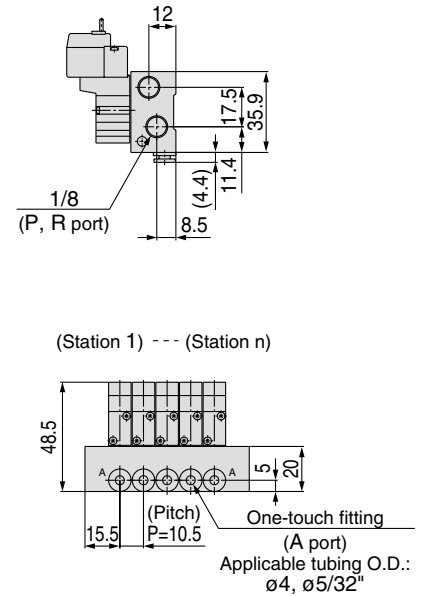

L plug connector (L)

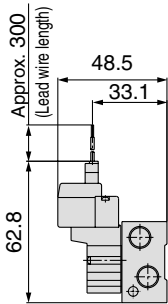

M plug connector (M)

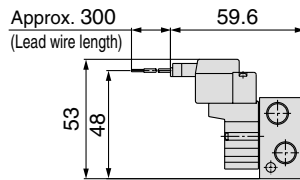

M8 connector (WO)

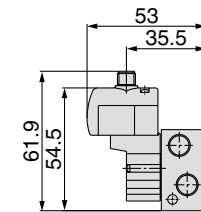

* Refer to back page 10 for dimensions with connector cable.

Type 42 Manifold: Side Ported (Pilot valve is on the A port side) / SS3YJ3-S42- Stations -M5, C4 N3 □-Q

Grommet (G)
For M5

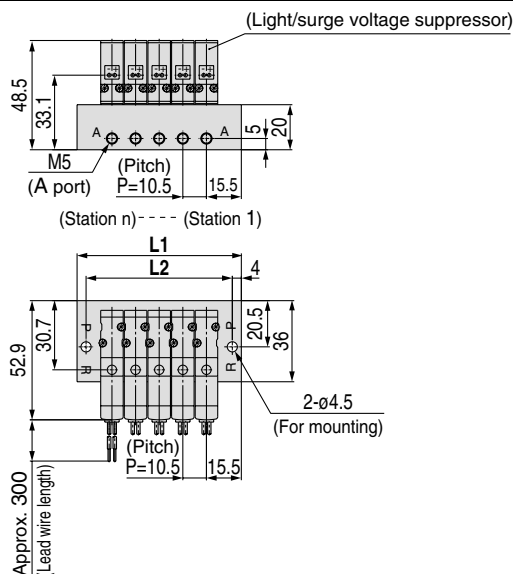

For C4 N3 □ (Built-in one-touch fitting)

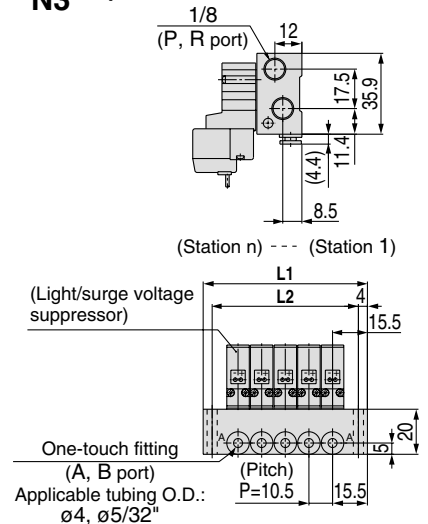

Station n	Station 2	3	4	5	6	7	8	9	10	11	12	13	14	15	16	17	18	19	Station 20
L1	41.5	52	62.5	73	83.5	94	104.5	115	125.5	136	146.5	157	167.5	178	188.5	199	209.5	220	230.5
L2	33.5	44	54.5	65	75.5	86	96.5	107	117.5	128	138.5	149	159.5	170	180.5	191	201.5	212	222.5

Series SYJ300

Type 20R Manifold: Top Ported (External Pilot Type)/SS3YJ3-20R- Stations -00□-Q

Grommet (G)

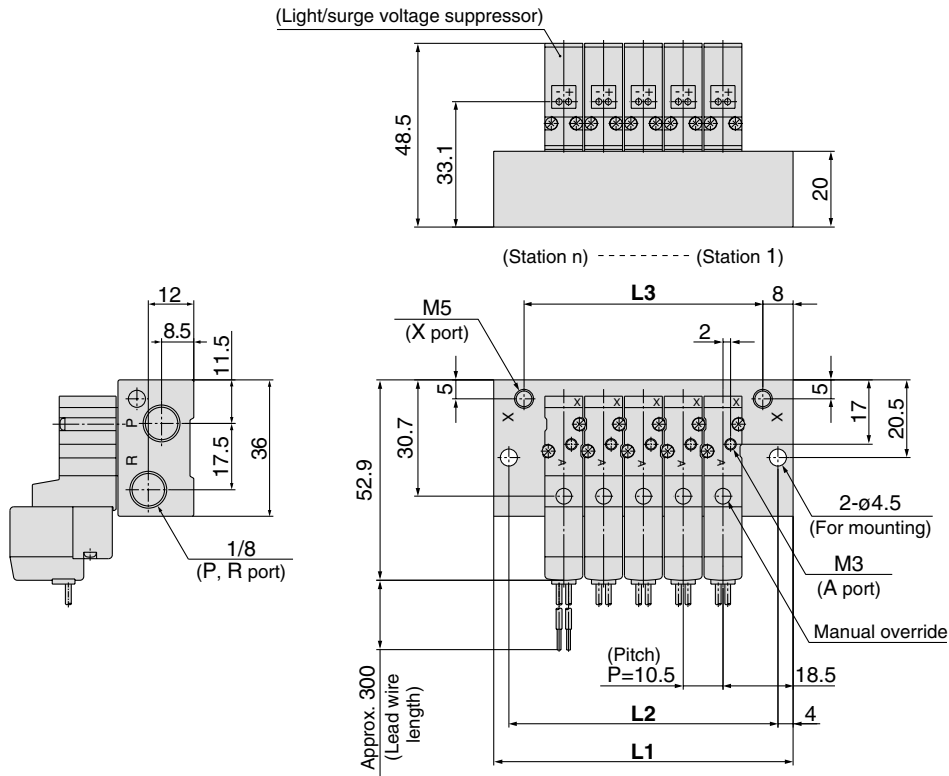

L plug connector (L)

M plug connector (M)

M8 connector (WO)

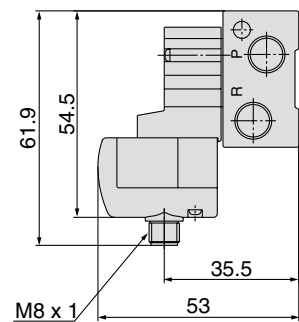
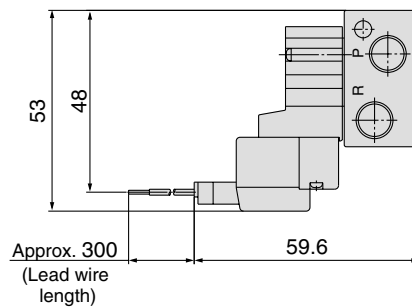
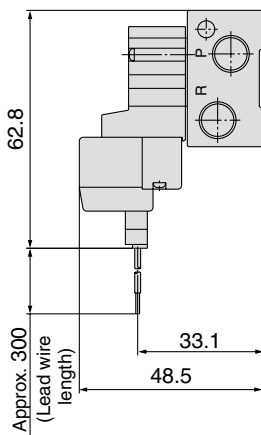

* Refer to back page 10 for dimensions with connector cable.

Station n	Station 2	3	4	5	6	7	8	9	10	11	12	13	14	15	16	17	18	19	Station 20
L1	47.5	58	68.5	79	89.5	100	110.5	121	131.5	142	152.5	163	173.5	184	194.5	205	215.5	226	236.5
L2	39.5	50	60.5	71	81.5	92	102.5	113	123.5	134	144.5	155	165.5	176	186.5	197	207.5	218	228.5
L3	31.5	42	52.5	63	73.5	84	94.5	105	115.5	126	136.5	147	157.5	168	178.5	189	199.5	210	220.5

Type 42R Manifold: Side Ported (External Pilot Type)/SS3YJ3-42R- Stations -M5, \square -Q

Grommet (G)
For M5

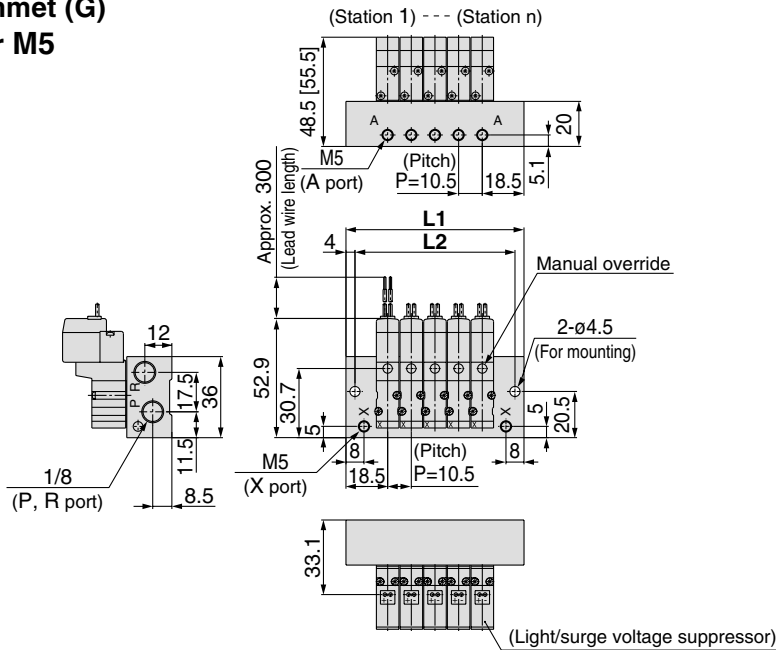

For \square (Built-in one-touch fitting)

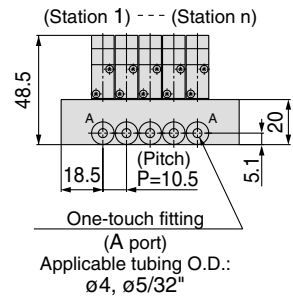
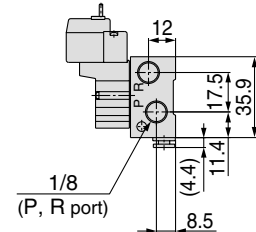

L plug connector (L)

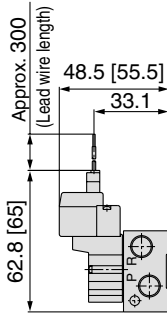

M plug connector (M)

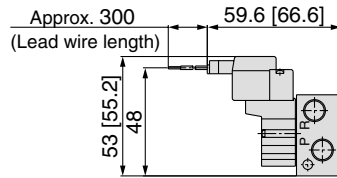

M8 connector (WO)

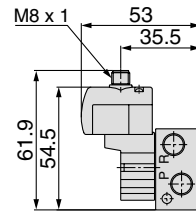

* Refer to back page 10 for dimensions with connector cable.

Type S42R Manifold: Side Ported (Pilot valve is on the A port side) / SS3YJ3-S42R- Stations -M5, \square -Q

Grommet (G)
For M5

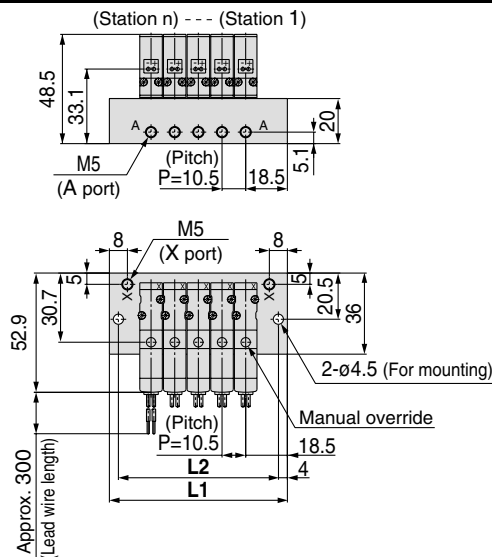

For \square (Built-in one-touch fitting)

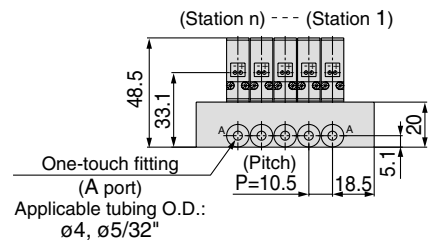
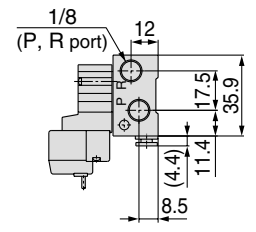

Station n	Station 2	3	4	5	6	7	8	9	10	11	12	13	14	15	16	17	18	19	Station 20
L1	47.5	58	68.5	79	89.5	100	110.5	121	131.5	142	152.5	163	173.5	184	194.5	205	215.5	226	236.5
L2	39.5	50	60.5	71	81.5	92	102.5	113	123.5	134	144.5	155	165.5	176	186.5	197	207.5	218	228.5

Rubber Seal 3 Port Pilot Solenoid Valve Series SYJ500



Refer to www.smcworld.com for details of products compatible with overseas standards.

Specifications

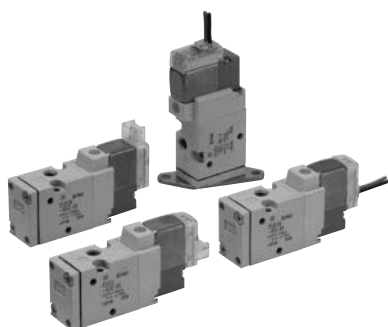

Body ported

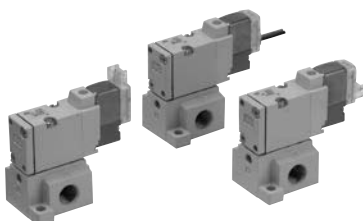

Base mounted

Fluid	Air	
Operating pressure range (MPa)	Internal pilot	0.15 to 0.7
Ambient and fluid temperature (°C) -10 to 50 (No freezing. Refer to back page 2.)		
Response time ms (at 0.5 MPa) ^{Note 1)} 25 or less		
Max. operating frequency (Hz) 5		
Manual override (Manual operation) Non-locking push type, push-turn locking slotted type, push-turn locking lever type		
Pilot exhaust method Individual exhaust for the pilot valve, common exhaust for the pilot and main valve		
Lubrication Not required		
Mounting orientation Unrestricted		
Shock/Vibration resistance (m/s²) ^{Note 2)} 150/30		
Enclosure Dust proof (* DIN terminal, M8 connector conforms to IP65.)		



* Based on IEC60529

Note 1) Based on dynamic performance test, JIS B 8374-1981. (Coil temperature: 20°C, at rated voltage, without surge voltage suppressor.)

Note 2) Impact resistance: No malfunction occurred when it is tested in the axial direction and at the right angles to the main valve and armature in both energised and de-energised states every once for each condition. (Value in the initial state)

Vibration resistance: No malfunction occurred in one sweep test between 45 and 2000 Hz. Test was performed to axis and right angle directions of the main valve and armature when pilot signal is ON and OFF. (Value in the initial state)

JIS Symbol

Internal pilot

SYJ51₄²

SYJ52₄²

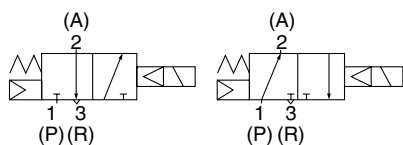

External pilot

SYJ51₄²R

SYJ52₄²R

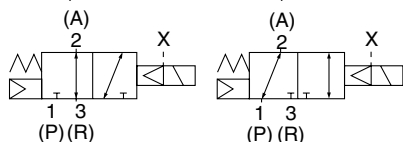

Solenoid Specifications

Electrical entry		Grommet (G), (H), L plug connector (L), M plug connector (M), DIN terminal (D), M8 connector (W)	
		G, H, L, M, W	D
Coil rated voltage (V)	DC	24, 12, 6, 5, 3	24, 12
	AC ^{50/60} Hz	-	100, 110, 200, 220
Allowable voltage fluctuation		±10% of rated voltage *	
Power consumption (W)	DC	Standard	0.35 (With light: 0.4 (DIN terminal with light: 0.45))
		With power saving circuit	0.1 (With light only)
Apparent power (VA) *	AC	100 V	0.78 (With light: 0.87)
		110 V	0.86 (With light: 0.97)
		[115 V]	[0.94 (With light: 1.07)]
		200 V	1.15 (With light: 1.30)
		220 V	1.27 (With light: 1.46)
		[230 V]	[1.39 (With light: 1.60)]
Surge voltage suppressor		Diode (DIN terminal, varistor when non-polar types)	
Indicator light		LED (Neon light when AC with DIN terminal)	



* In common between 110 VAC and 115 VAC, and between 220 VAC and 230 VAC.

* For 115 VAC and 230 VAC, the allowable voltage is -15% to +5% of rated voltage.

* S, Z and T type (with power saving circuit) should be used within the following allowable voltage fluctuation range due to a voltage drop caused by the internal circuit.

S and Z type: 24 VDC: -7% to +10%

12 VDC: -4% to +10%

T type: 24 VDC: -8% to +10%

12 VDC: -6% to +10%



Made to Order

(For details, refer to pages 57 through to 59.)

Flow Characteristics/Weight

Valve model		Type of actuation	Port size	Flow characteristics								Weight (g) ^{Note)}			
				1→2 (P→A)				2→3 (A→R)				Grommet	L/M plug connector	DIN terminal	M8 connector
				C [dm ³ /(s bar)]	b	Cv	Q _l [min(ANR)]*	C [dm ³ /(s bar)]	b	Cv	Q _l [min(ANR)]*				
Body ported	SYJ512	N.C.	M5	0.53	0.45	0.14	150	0.47	0.39	0.12	127	46	47	68	51
	SYJ522	N.O.		0.66	0.45	0.18	186	0.66	0.45	0.18	186				
Base mounted (with sub-plate)	SYJ514	N.C.	1/8	1.2	0.41	0.32	329	1.1	0.46	0.32	313	60 (46)	61 (47)	82 (68)	65 (51)
	SYJ524	N.O.		1.3	0.37	0.33	346	1.2	0.48	0.34	347				



Note) Value for DC. Add 1 g for AC. (): Without sub-plate.

* These values have been calculated according to ISO 6358 and represent the flow rate measured in standard conditions at an upstream pressure of 0.6MPa (relative pressure) and a differential pressure of 0.1MPa.

External Pilot

SYJ500R

Pilot valve pressure is supplied separately from the main valve pressure through the use of a separate supply port. It can be used in the vacuum (up to -100 kPa) or low pressure line with 0.15 MPa or less.

Specifications

Applicable model	Base mounted (SYJ514R, SYJ524R)	
Operating pressure range MPa	Main pressure	-100 kPa to 0.7
	External pilot pressure	0.15 to 0.7

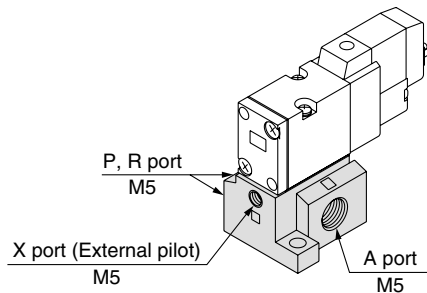

Note 1) For manifold base, refer to page 21.

Note 2) External pilot type body ported valves (SYJ5□2R) can only be used on the manifold. For body ported models with the external pilot option, please refer to page 59.

How to Order

Rated voltage

DC

5	24 VDC
6	12 VDC
V	6 VDC
S	5 VDC
R	3 VDC

* DC specifications of type D and DO is only available with 12 and 24 VDC.

AC (50/60 Hz)

1	100 VAC
2	200 VAC
3	110 VAC [115 VAC]
4	220 VAC [230 VAC]

* AC specification is only available with D, DO type.

Type of actuation

1	Normally closed
2	Normally open

Light/surge voltage suppressor

Electrical entry for G, H, L, W

-	Without light/surge voltage suppressor
S	With surge voltage suppressor
Z	With light/surge voltage suppressor
R	With surge voltage suppressor (Non-polar type)
U	With light/surge voltage suppressor (Non-polar type)

* Power saving circuit is only available in the "Z" type.

Electrical entry for D

-	Without light/surge voltage suppressor
S	With surge voltage suppressor (Non-polar type)
Z	With light/surge voltage suppressor (Non-polar type)

* DOZ is not available.
* For AC voltage valves there is no "S" option. It is already built-in to the rectifier circuit.

Bracket

-:	Without bracket
F:	With bracket

* Bracket is mounted.
* External pilot type is not available.

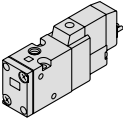

(For manifold type 20, 21R)

Body ported SYJ5 **1** **2** **5** **M** **M5** **Q**

Base mounted SYJ5 **1** **4** **5** **M** **01** **Q**

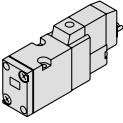

(For sub-plate style, manifold type 40, 40R, 41, 41R)

Coil specifications

-	Standard
T	With power saving circuit (24, 12 VDC only)

* Power saving circuit is not available in the case of D, DO, W□ type.

Manual override

-: Non-locking push type

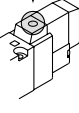

D: Push-turn locking slotted type

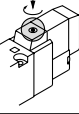

E: Push-turn locking lever type

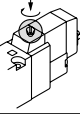

Port size

-: Without sub-plate **01:** 1/8 port

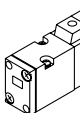

(With gasket and screws)

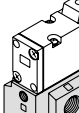

Thread type

-	Rc
F	G
N	NPT
T	NPTF

Body option

-: Individual pilot exhaust type

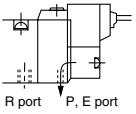

R port P, E port

M: Common exhaust for the pilot and main valve

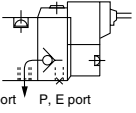

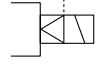

R port P, E port

R: External pilot type*

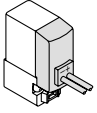
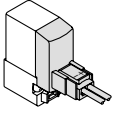
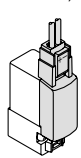
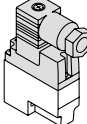

* SYJ5□2R is only for manifold use.

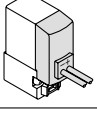
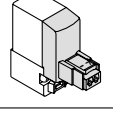
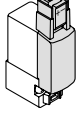
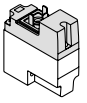
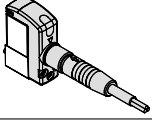
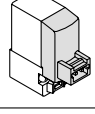
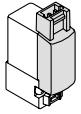
24, 12, 6, 5, 3 VDC					24, 12 VDC/ 100, 110, 200, 220 VAC	24, 12, 6, 5, 3 VDC
Grommet	L plug connector	M plug connector	DIN terminal	M8 connector *		
G: Lead wire length 300 mm	L: With lead wire (Length 300 mm)	M: With lead wire (Length 300 mm)	D: With connector	WO: Without connector cable		
						
H: Lead wire length 600 mm	LN: Without lead wire	MN: Without lead wire	DO: Without connector	W□: With connector cable (Note 1)		
						
	LO: Without connector	MO: Without connector				
						

Note) When placing an order for body ported solenoid valve as a single unit, mounting bolt for manifold and gasket are not attached. Order them separately, if necessary. (For details, refer to catalogue on page 22.)

Note 1) Enter the cable length symbols in □. Please be sure to fill in the blank referring to back page 10.

* LN, MN type: with 2 sockets.
* DIN terminal type "Y" which conforms to EN-175301-803C (former DIN43650C) is also available. For details, refer to page 57.
* For connector cable of M8 connector, refer to back page 9.
* Connector M8 type "WA" conforming to IEC 60947-5-2 standard, is also available. For details, see page 58.

Construction

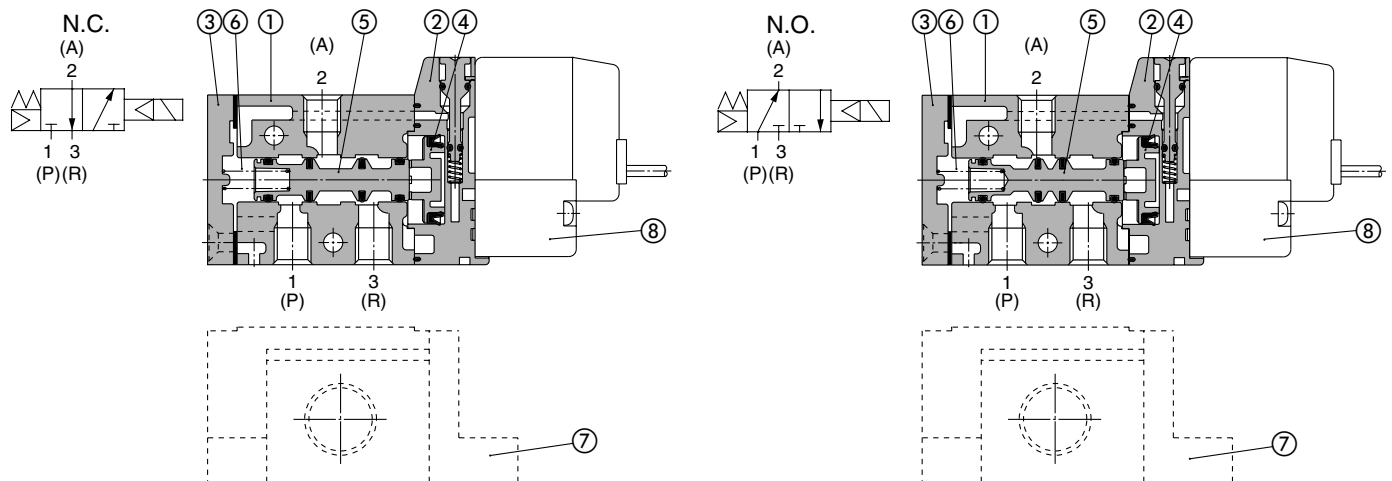

Component Parts

No.	Description	Material	Note
1	Body	Aluminum die-casted	White
2	Piston plate	Resin	White
3	End cover	Aluminum die-casted	White
4	Piston	Resin	—
5	Spool valve assembly	—	—
6	Spool spring	Stainless steel	—

Replacement Parts

No.	Description	No.	Note
7	Sub-plate	SYJ500-9-1-Q	Zinc die-casted
8	Pilot valve	V111(T)-□□□□	
—	Bracket assembly	SYJ5000-13-3A	

How to Order Pilot Valve Assembly

V111 □ 5 G □

Coil specifications

-	Standard
T	With power saving circuit (24, 12 VDC only)

* Power saving circuit is not available in the case of W□ type.

Rated voltage

5	24 VDC
6	12 VDC
V	6 VDC
S	5 VDC
R	3 VDC

Light/surge voltage suppressor

-	Without light/surge voltage suppressor
S	With surge voltage suppressor
Z	With light/surge voltage suppressor
R	With surge voltage suppressor (Non-polar type)
U	With light/surge voltage suppressor (Non-polar type)

* Power saving circuit is only available in the "Z" type.

Electrical entry

G	Grommet, 300 mm lead wire	
H	Grommet, 600 mm lead wire	
L	L plug connector	With lead wire
LN		Without lead wire
LO		Without connector
M	M plug connector	With lead wire
MN		Without lead wire
MO		Without connector
WO	M8	Without connector cable
W□	connector	With connector cable ^{Note 1)}

* For connector cable of M8 connector, refer to back page 9.

How to Order Connector Assembly for L/M Plug Connector

For DC: SY100-30-4A-□

Without lead wire: SY100-30-A
(with connector and 2 of sockets only)

Lead wire length

-	300 mm
6	600 mm
10	1000 mm
15	1500 mm
20	2000 mm
25	2500 mm
30	3000 mm
50	5000 mm

Note 1) Enter the cable length symbols in □. Please be sure to fill in the blank referring to back page 10.

V115 □ 5 D □

Rated voltage

5	24 VDC
6	12 VDC
1	100 VAC 50/60 Hz
2	200 VAC 50/60 Hz
3	110 VAC 50/60 Hz [115 VAC 50/60 Hz]
4	220 VAC 50/60 Hz [230 VAC 50/60 Hz]

* DC specifications of type D and DO is only available with 12 and 24 VDC.

* Power saving circuit is not available in the case of D or DO type.

Light/surge voltage suppressor

-	Without light/surge voltage suppressor
S	With surge voltage suppressor (Non-polar type)
Z	With light/surge voltage suppressor (Non-polar type)

* DOZ is not available.
* For AC voltage valves there is no "S" option. It is already built-in to the rectifier circuit.

Electrical entry

D	DIN	With connector
DO	terminal	Without connector

* Do not replace V111 (G, H, L, M, W) to V115 (DIN terminal) and vice versa when replacing pilot valve assembly only.

How to Order M8 Connector Cable

V100-49-1-□

Cable length

1	300 mm
2	500 mm
3	1000 mm
4	2000 mm
7	5000 mm

Series SYJ500

Body Ported

Grommet (G), (H): SYJ5□2-□^G□□-M5-Q

With bracket:
SYJ5□2-□^G□□-M5-F-Q

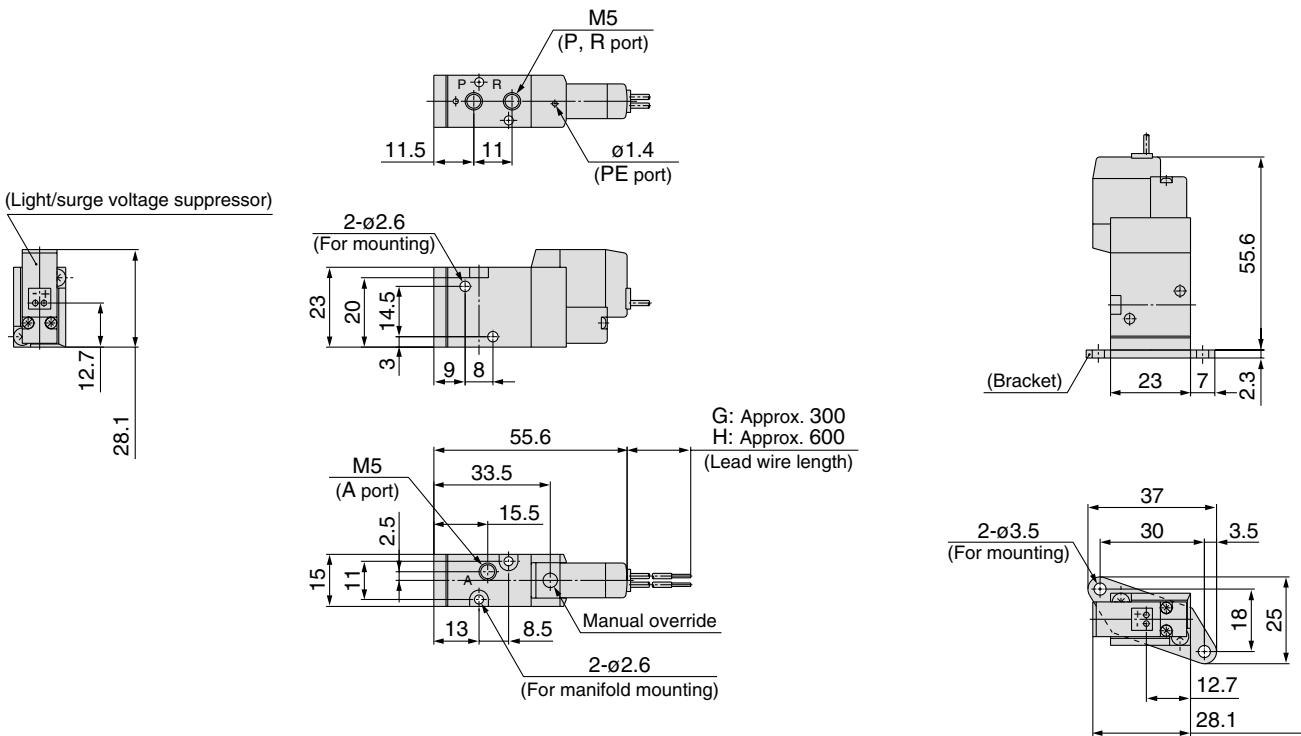

L plug connector (L):
SYJ5□2-□L□□-M5 (-F)-Q

M plug connector (M):
SYJ5□2-□M□□-M5 (-F)-Q

DIN terminal (D):
SYJ5□2-□D□□-M5 (-F)-Q

M8 connector (WO):
SYJ5□2-□WO□□-M5 (-F)-Q

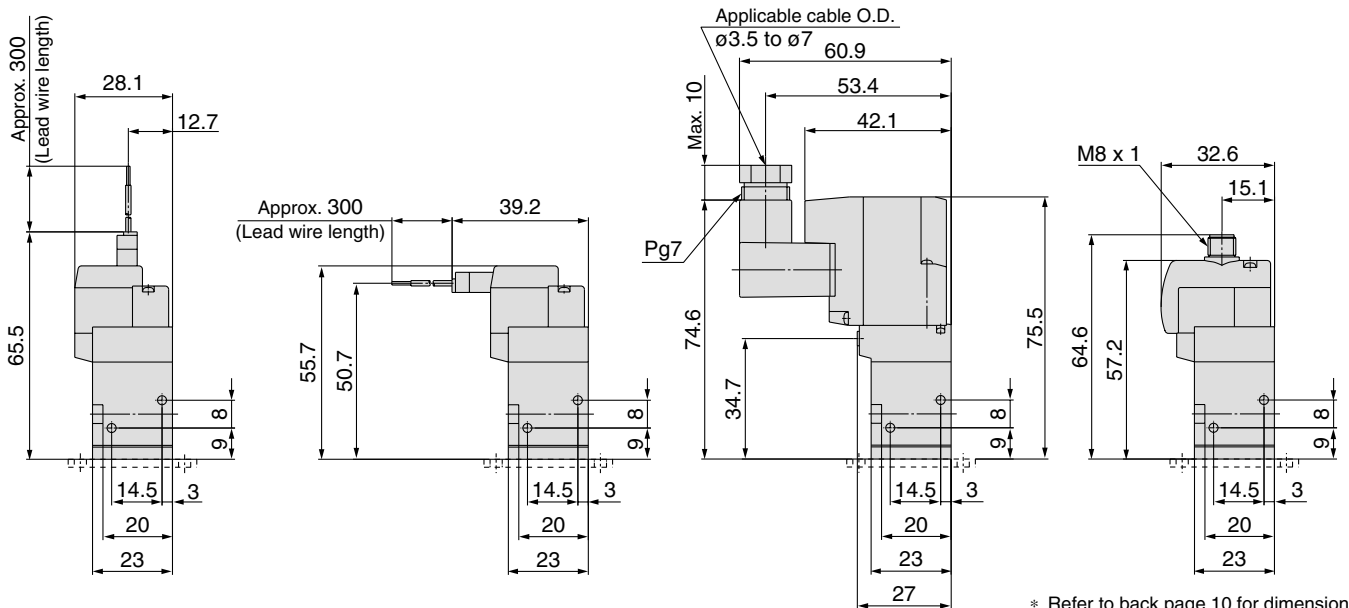

* Refer to back page 10 for dimensions with connector cable.

Base Mounted (With Sub-plate)

Grommet (G), (H): SYJ5□4-□^G□□-01□-Q

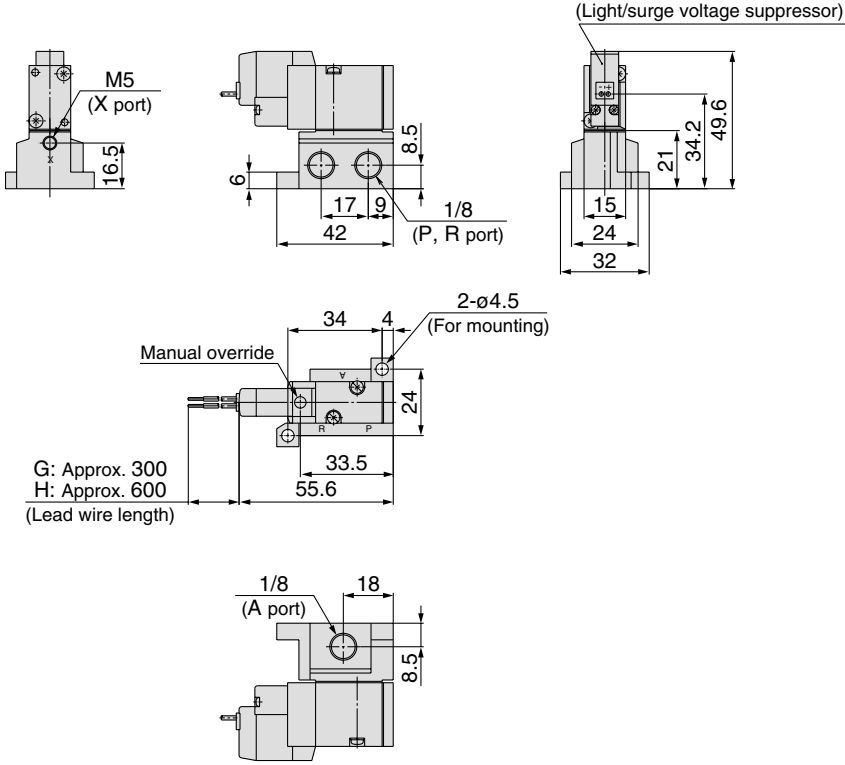

L plug connector (L):
SYJ5□4-□L□□-01□-Q

M plug connector (M):
SYJ5□4-□M□□-01□-Q

DIN terminal (D):
SYJ5□4-□D□□-01□-Q

M8 connector (WO):
SYJ5□4-□WO□□-01□-Q

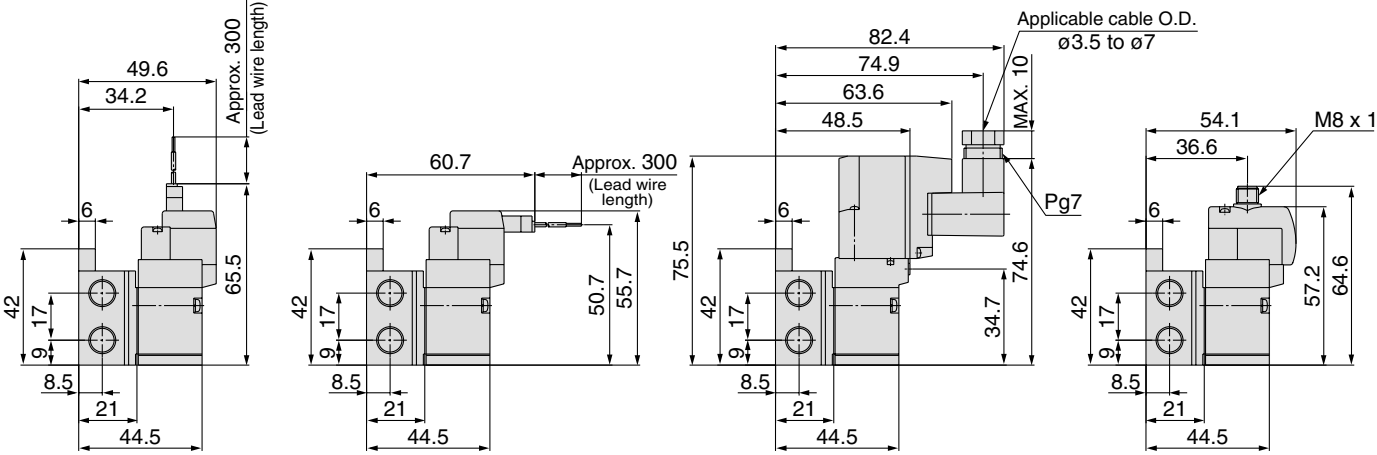

* Refer to back page 10 for dimensions with connector cable.

Series SYJ500 Manifold Specifications

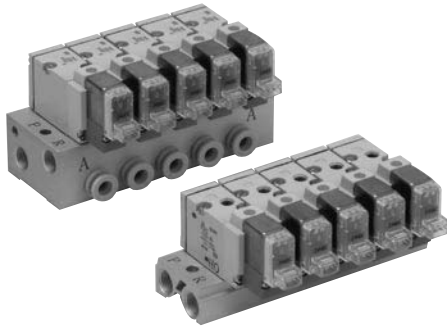

Manifold Specifications

Model	For internal pilot	Type 20	Type 40	Type 41
	For external pilot	Type 21R	Type 40R	Type 41R
Manifold type	Single base/B mount			
P (SUP), R (EXH)	Common SUP, common EXH			
Valve stations	2 to 20 stations			
A port Porting specifications	Location	Valve	Base	
	Direction	Top	Bottom	Side
Port size	P, R port	1/8	1/8	1/8
	A port	M5	M5 1/8	M5 x 0.8, 1/8, C4 (One-touch fitting for ø4), C6 (One-touch fitting for ø6)
	X port ^{Note)}	M5	M5	M5

Note) Only for external pilot

Flow Characteristics

Manifold			Port size		Flow characteristics							
					1→2 (P→A)				2→3 (A→R)			
1(P), 3(R) port	2(A) port	C [dm ³ /(sbar)]	b	Cv	Q[l/min(ANR)]*	C [dm ³ /(sbar)]	b	Cv	Q[l/min(ANR)]*			
Body ported for internal pilot	Type SS3YJ5-20	SYJ5□2	1/8	M5	0.47	0.43	0.13	131	0.74	0.32	0.19	191
Base mounted for internal pilot	Type SS3YJ5-40-M5	SYJ5□4	1/8	M5	0.71	0.52	0.21	212	0.81	0.28	0.20	203
	Type SS3YJ5-40-01		1/8	1/8	0.98	0.36	0.25	259	0.92	0.24	0.22	226
	Type SS3YJ5-41-M5		1/8	M5	0.71	0.49	0.20	207	0.80	0.23	0.19	195
	Type SS3YJ5-41-01		1/8	1/8	1.0	0.37	0.26	266	0.96	0.25	0.24	237
	Type SS3YJ5-41-C4		1/8	C4	0.68	0.35	0.17	179	1.0	0.25	0.24	247
	Type SS3YJ5-41-C6		1/8	C6	1.0	0.27	0.25	250	1.0	0.30	0.26	254
Body ported for external pilot	Type SS3YJ5-21R	SYJ5□2R	1/8	M5	0.47	0.43	0.13	131	0.74	0.32	0.19	191
Base mounted for external pilot	Type SS3YJ5-40R-M5	SYJ5□4R	1/8	M5	0.71	0.52	0.21	212	0.81	0.28	0.20	203
	Type SS3YJ5-40R-01		1/8	1/8	0.98	0.36	0.25	259	0.92	0.24	0.22	226
	Type SS3YJ5-41R-M5		1/8	M5	0.71	0.49	0.20	207	0.80	0.23	0.19	195
	Type SS3YJ5-41R-01		1/8	1/8	1.0	0.37	0.26	266	0.96	0.25	0.24	237
	Type SS3YJ5-41R-C4		1/8	C4	0.68	0.35	0.17	179	1.0	0.25	0.24	247
	Type SS3YJ5-41R-C6		1/8	C6	1.0	0.27	0.25	259	1.0	0.30	0.26	254

Note) Value at manifold base mounted, 2 position single operating.
* These values have been calculated according to ISO 6358 and represent the flow rate measured in standard conditions at an upstream pressure of 0.6MPa (relative pressure) and a differential pressure of 0.1MPa.

How to Order Manifold (Example)

Instruct by specifying the valves and blanking plate assembly to be mounted on the manifold along with the manifold base model no.

(Example)

SS3YJ5-20-03-Q 1 set (manifold base) SS3YJ5-41R-03-C6-Q 1 set (manifold base)

*SYJ512-5LZ-M5-Q 2 sets (valve) SYJ514R-5G-Q 2 sets (valve)

*SYJ500-10-1A-Q 1 set (blanking plate assembly) SYJ500-10-3A-Q 1 set (blanking plate assembly)

↳ The asterisk denotes the symbol for assembly. Prefix it to the part nos. of the solenoid valve, etc.

Combinations of Solenoid Valve, Manifold Gasket and Manifold Base

Blanking Plate Assembly

Body ported (Type SYJ5□2(R))-Q

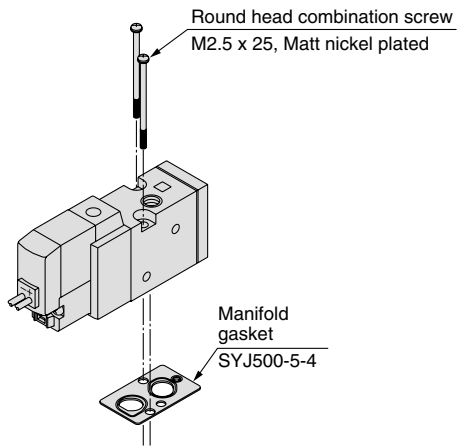

Applicable base
SS3YJ5-21R-Q
SS3YJ5-20-Q
Manifold base

Base mounted (Type SYJ5□4(R))-Q

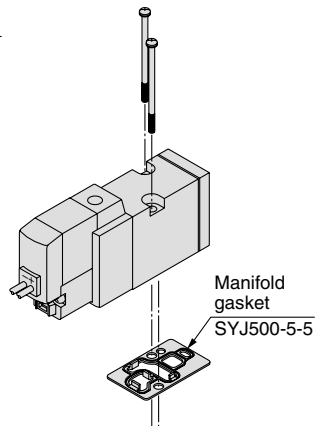

Applicable base
Sub-plate
SS3YJ5-40-Q
SS3YJ5-41-Q
SS3YJ5-40R-Q
SS3YJ5-41R-Q } Manifold base

Model no.: SYJ500-10-3A-Q

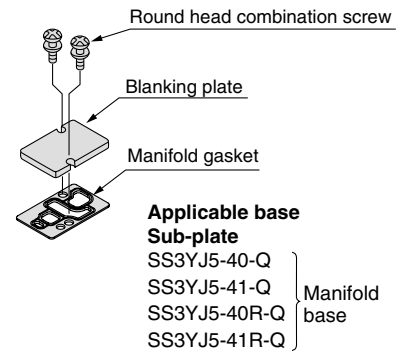

Model no.: SYJ500-10-1A-Q

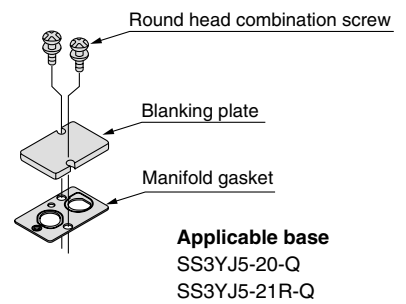

⚠ Caution

Mounting screw tightening torques

M2.5: 0.45 N·m

Use caution to the assembly orientation for solenoid valves (blanking plate) and manifold gasket.

Series SYJ500

Manifold for Internal Pilot Type

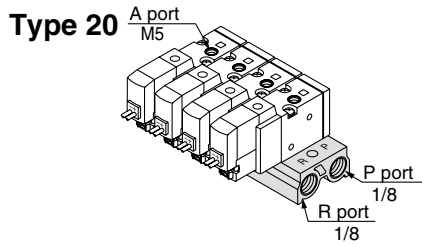

How to Order

SS3YJ5-20-05 [] [] -Q

Stations	P, R port thread type	Bracket
02 2 stations	- Rc	- Without bracket
:	00F G	F With bracket
20 20 stations	00N NPT	
	00T NPTF	

Applicable solenoid valve
 SYJ512--□□□□-M5-Q
 SYJ512M--□□□□-M5-Q
 SYJ522--□□□□-M5-Q
 SYJ522M--□□□□-M5-Q

Applicable blanking plate assembly
 SYJ500-10-1A-Q



Note) For more than 6 stations, supply air to both sides of P port and exhaust air from both sides of R port.

Type 40

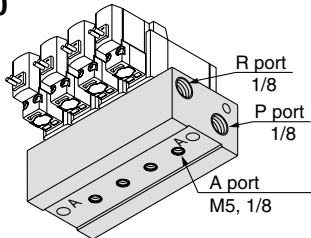

How to Order

SS3YJ5-40-05 [] **M5** [] -Q

Stations	A port size	P, R port thread type
02 2 stations	M5 M5	- Rc
:	01 1/8	F G
20 20 stations		N NPT
		T NPTF

Applicable solenoid valve
 SYJ514--□□□□-Q
 SYJ514M--□□□□-Q
 SYJ524--□□□□-Q
 SYJ524M--□□□□-Q

Applicable blanking plate assembly
 SYJ500-10-3A-Q



Note) For more than 9 stations, supply air to both sides of P port and exhaust air from both sides of R port.

Type 41

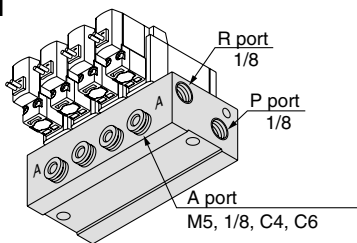

How to Order

SS3YJ5-41-05 [] **C6** [] -Q

Stations	A port size	P, R port thread type
02 2 stations	M5 M5	- Rc
:	01 1/8	F G
20 20 stations	C4 ø4 one-touch fitting	N NPT
	C6 ø6 one-touch fitting	T NPTF
	N3 ø5/32" one-touch fitting	
	N7 ø1/4" one-touch fitting	

Applicable solenoid valve
 SYJ514--□□□□-Q
 SYJ514M--□□□□-Q
 SYJ524--□□□□-Q
 SYJ524M--□□□□-Q

Applicable blanking plate assembly
 SYJ500-10-3A-Q



Note) For more than 9 stations, supply air to both sides of P port and exhaust air from both sides of R port.

Manifold for External Pilot Type

Pilot valve pressure is supplied separately from the main valve pressure through the use of a separate supply port. It can be used in the vacuum (up to -100 kPa) or low pressure line with 0.15 MPa or less.

Type 21R

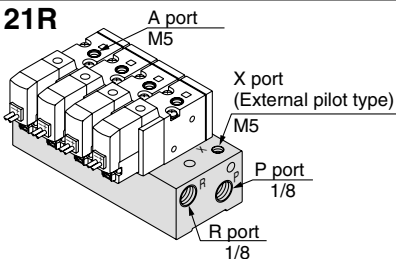

How to Order

SS3YJ5-21R-05 [] [] -Q

Stations	P, R port thread type
02 2 stations	- Rc
:	00F G
20 20 stations	00N NPT
	00T NPTF

Applicable solenoid valve
 SYJ512R--□□□□-M5-Q
 SYJ522R--□□□□-M5-Q

Applicable blanking plate assembly
 SYJ500-10-1A-Q



Note) For more than 9 stations, supply/exhaust air to/from both sides of P and R port

Type 40R

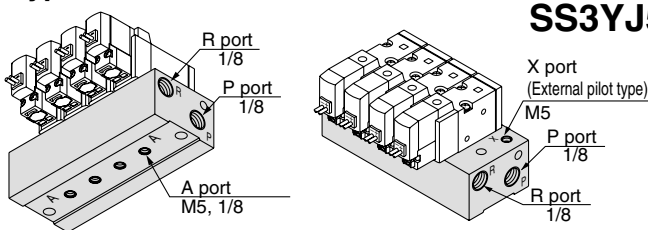

How to Order

SS3YJ5-40R-05 [] **01** [] -Q

Stations	A port size	P, R port thread type
02 2 stations	M5 M5	- Rc
:	01 1/8	F G
20 20 stations		N NPT
		T NPTF

Applicable solenoid valve
 SYJ514R--□□□□-Q
 SYJ524R--□□□□-Q

Applicable blanking plate assembly
 SYJ500-10-3A-Q



Note) For more than 9 stations, supply/exhaust air to/from both sides of P and R port

Type 41R

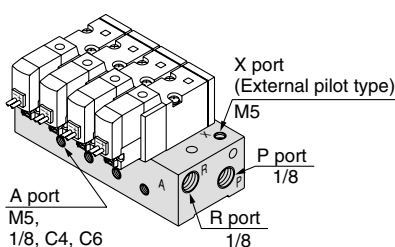

How to Order

SS3YJ5-41R-05 [] **M5** [] -Q

Stations	A port size	P, R port thread type
02 2 stations	M5 M5	- Rc
:	01 1/8	F G
20 20 stations	C4 ø4 one-touch fitting	N NPT
	C6 ø6 one-touch fitting	T NPTF
	N3 ø5/32" one-touch fitting	
	N7 ø1/4" one-touch fitting	

Applicable solenoid valve
 SYJ514R--□□□□-Q
 SYJ524R--□□□□-Q

Applicable blanking plate assembly
 SYJ500-10-3A-Q



Note) For more than 9 stations, supply/exhaust air to/from both sides of P and R port

Type 20 Manifold: Top Ported/SS3YJ5-20- Stations -00 □ (-F)-Q

Grommet (G)

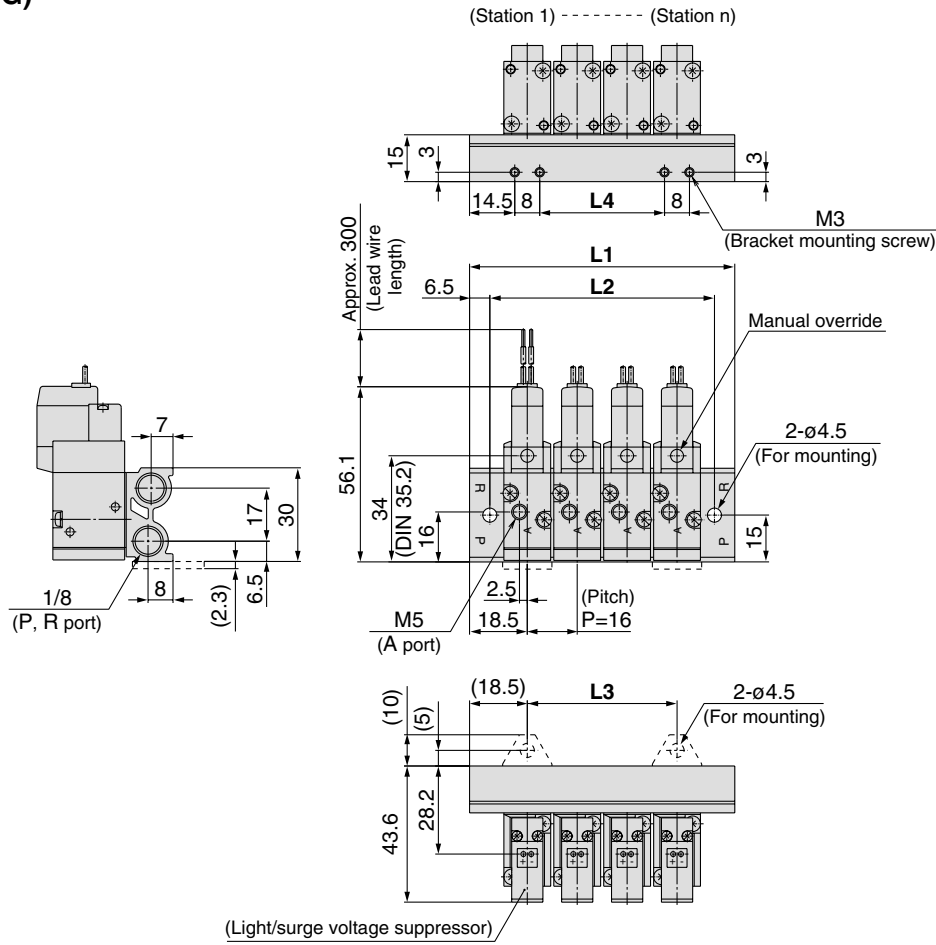

L plug connector (L)

M plug connector (M)

DIN terminal (D)

M8 connector (WO)

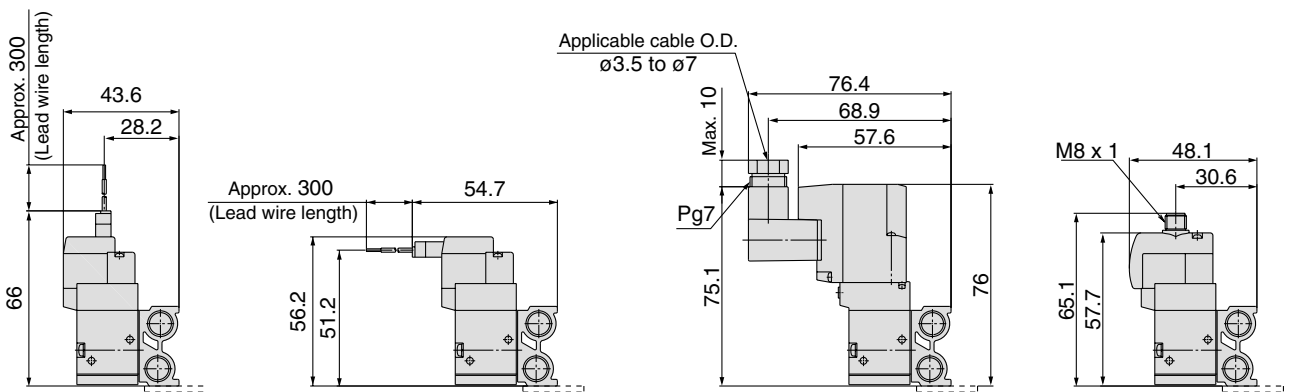

* Refer to back page 10 for dimensions with connector cable.

Station n	Station 2	3	4	5	6	7	8	9	10	11	12	13	14	15	16	17	18	19	Station 20
L1	53	69	85	101	117	133	149	165	181	197	213	229	245	261	277	293	309	325	341
L2	40	56	72	88	104	120	136	152	168	184	200	216	232	248	264	280	296	312	328
L3	16	32	48	64	80	96	112	128	144	160	176	192	208	224	240	256	272	288	304
L4	8	24	40	56	72	88	104	120	136	152	168	184	200	216	232	248	264	280	296

Series SYJ500

Type 40 Manifold: Bottom Ported/SS3YJ5-40-Stations-M5, 01□-Q

Grommet (G)

For M5

For 1/8

(Station n) ----- (Station 1)

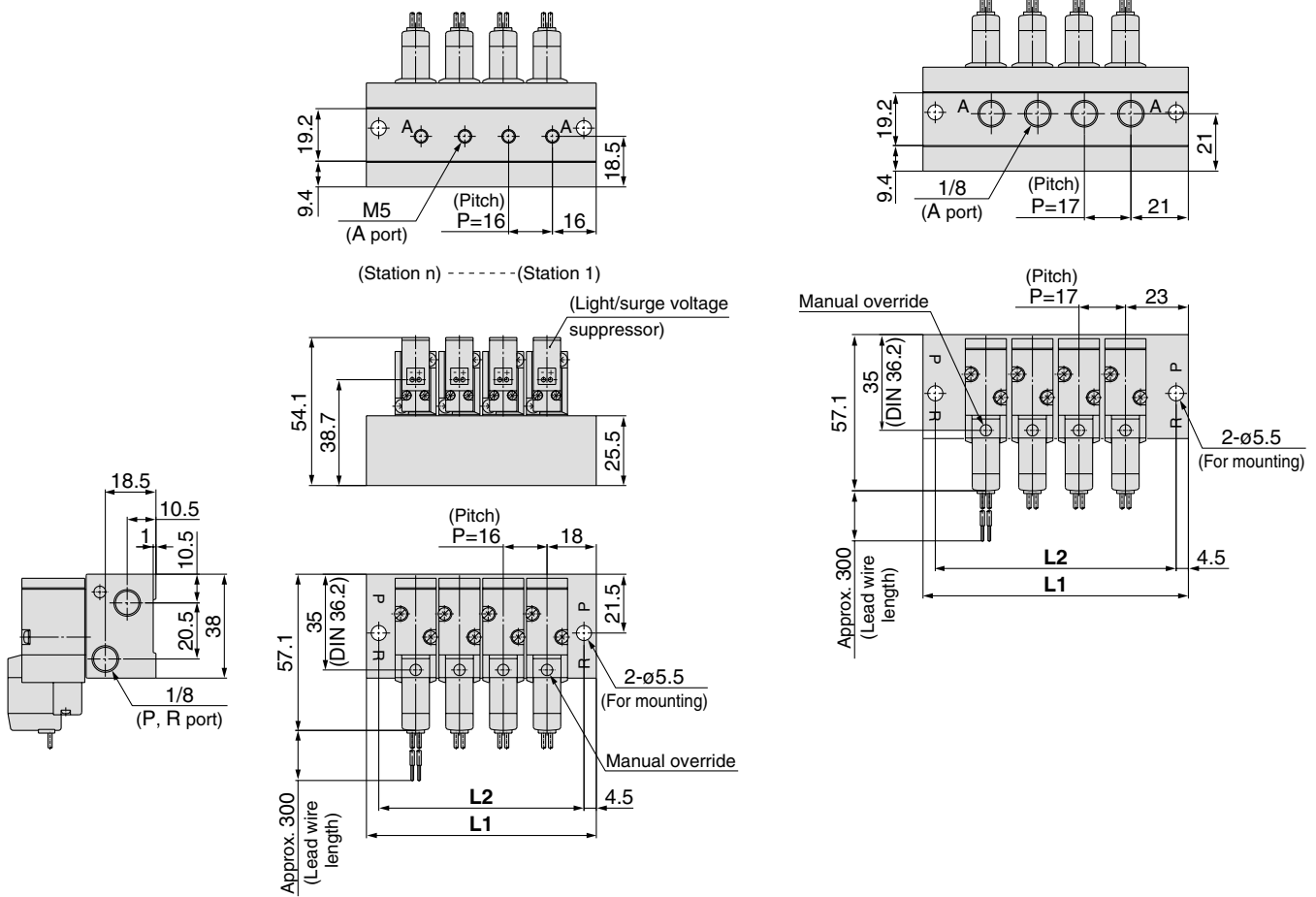

L plug connector (L)

M plug connector (M)

DIN terminal (D)

M8 connector (WO)

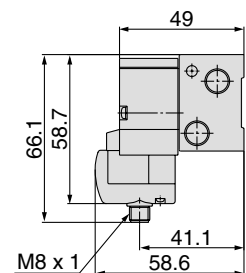
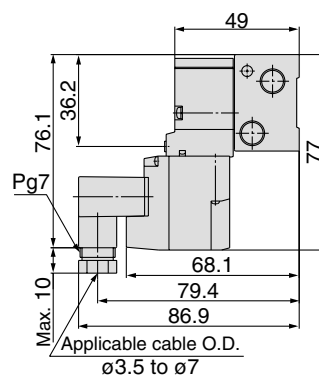
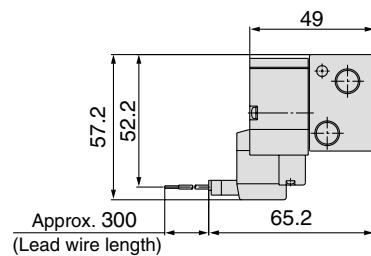
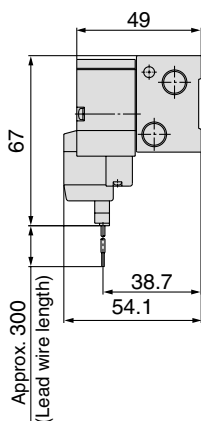

* Refer to back page 10 for dimensions with connector cable.

Port size	Station n	Station 2	3	4	5	6	7	8	9	10	11	12	13	14	15	16	17	18	19	Station 20
M5	L1	52	68	84	100	116	132	148	164	180	196	212	228	244	260	276	292	308	324	340
	L2	43	59	75	91	107	123	139	155	171	187	203	219	235	251	267	283	299	315	331
1/8	L1	63	80	97	114	131	148	165	182	199	216	233	250	267	284	301	318	335	352	369
	L2	54	71	88	105	122	139	156	173	190	207	224	241	258	275	292	309	326	343	360

Type 41 Manifold: Side Ported/SS3YJ5-41- Stations C4, N3
C6, N7 □-Q

Grommet (G)

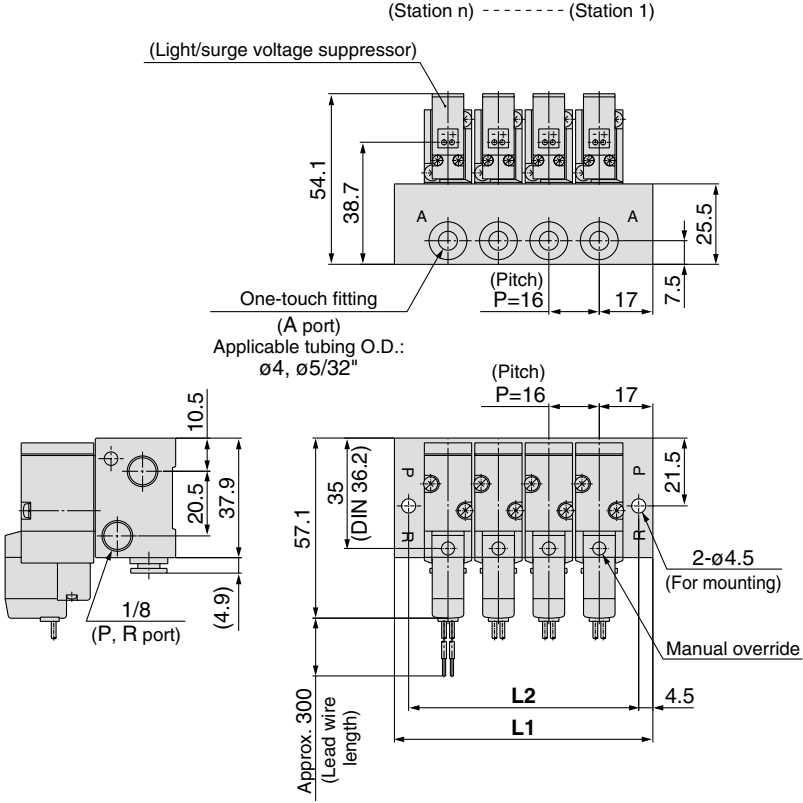

L plug connector (L)

M plug connector (M)

DIN terminal (D)

M8 connector (WO)

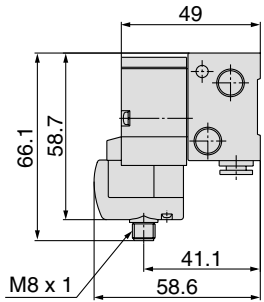
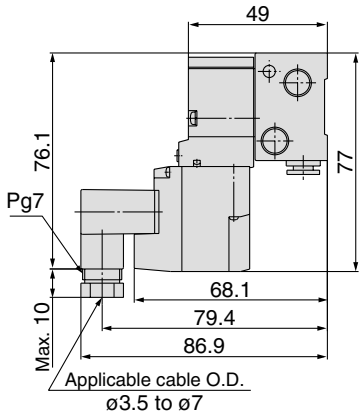
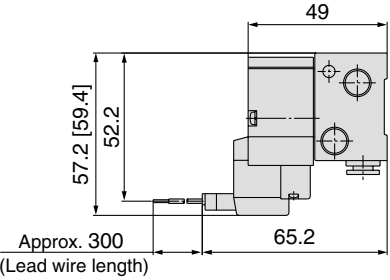
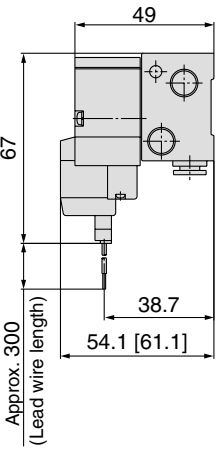

* Refer to back page 10 for dimensions with connector cable.

Port size	Station n	Station 2	3	4	5	6	7	8	9	10	11	12	13	14	15	16	17	18	19	Station 20
One-touch fitting	L1	50	66	82	98	114	130	146	162	178	194	210	226	242	258	274	290	306	322	338
	L2	41	57	73	89	105	121	137	153	169	185	201	217	233	249	265	281	297	313	329

Series SYJ500

Type 41 Manifold: Side Ported/SS3YJ5-41- Stations -M5, 01 □-Q

Grommet (G) For M5

For 1/8

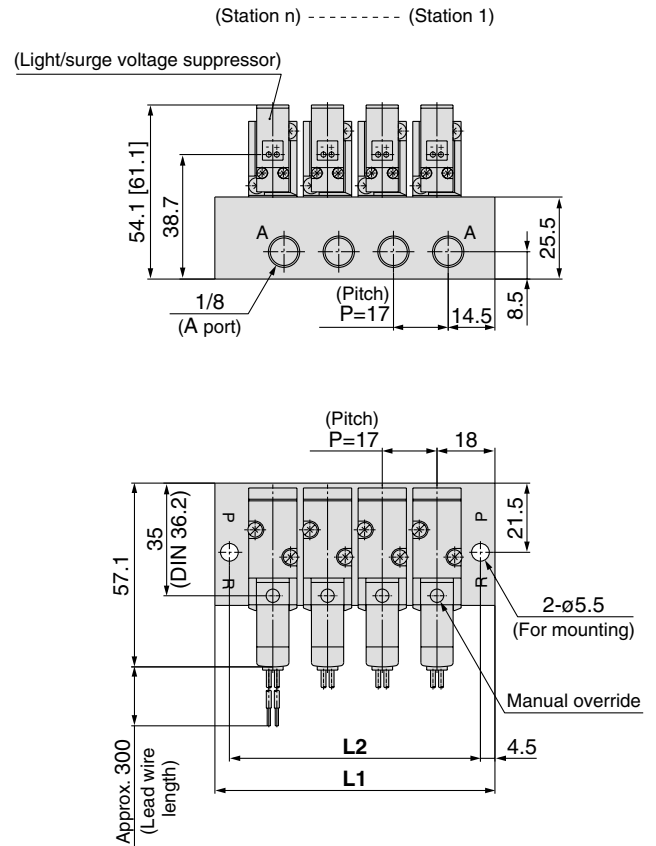
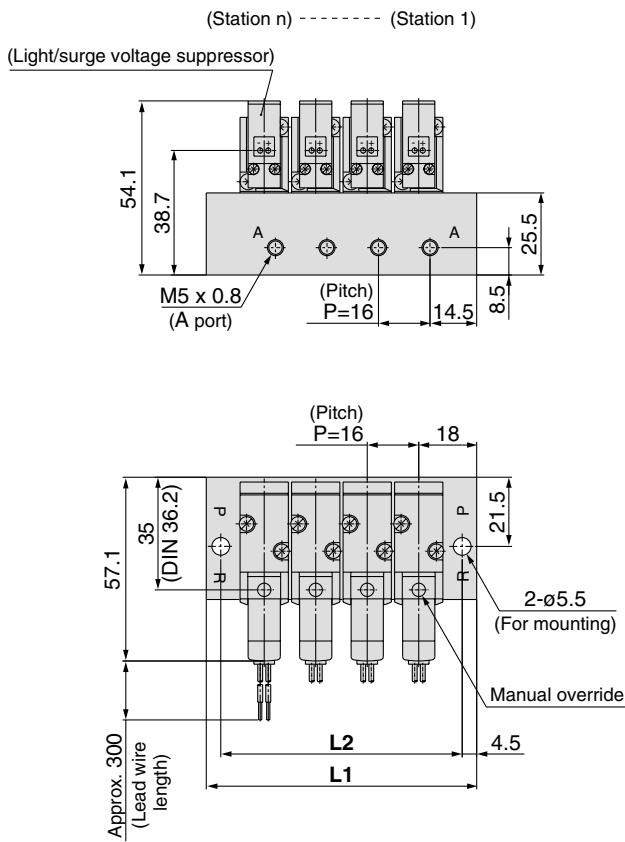

Port size	Station n	Station 2	3	4	5	6	7	8	9	10	11	12	13	14	15	16	17	18	19	Station 20
M5	L1	52	68	84	100	116	132	148	164	180	196	212	228	244	260	276	292	308	324	340
	L2	43	59	75	91	107	123	139	155	171	187	203	219	235	251	267	283	299	315	331
1/8	L1	53	70	87	104	121	138	155	172	189	206	223	240	257	274	291	308	325	342	359
	L2	44	61	78	95	112	129	146	163	180	197	214	231	248	265	282	299	316	333	350

Type 21R Manifold: Top Ported (External Pilot Type)/SS3YJ5-21R- Stations -00 □ -Q

Grommet (G)

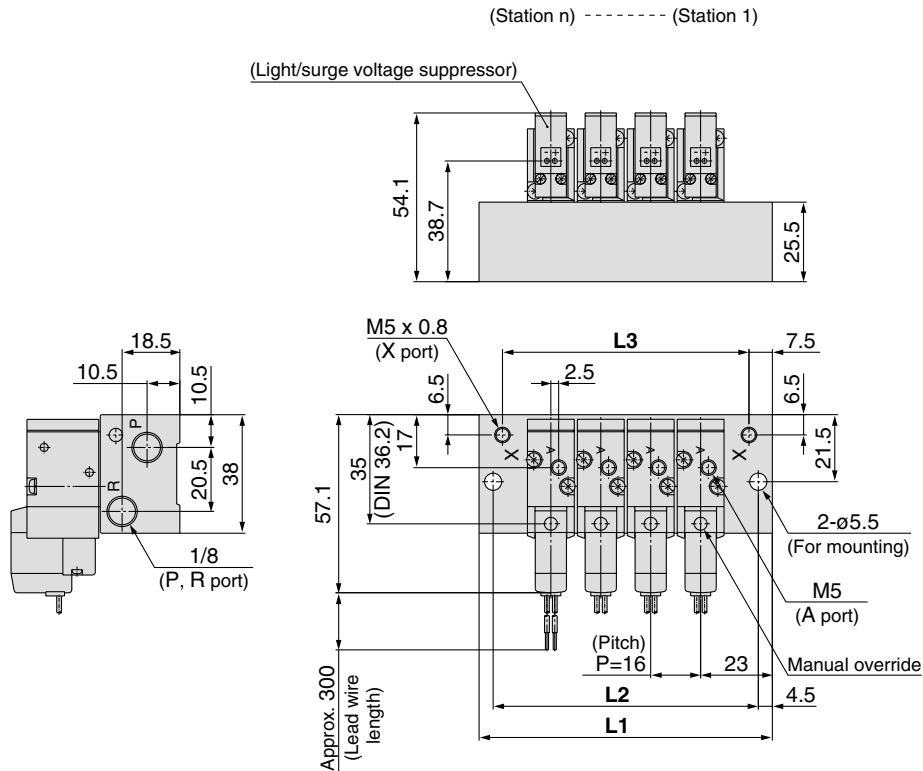

L plug connector (L)

M plug connector (M)

DIN terminal (D)

M8 connector (WO)

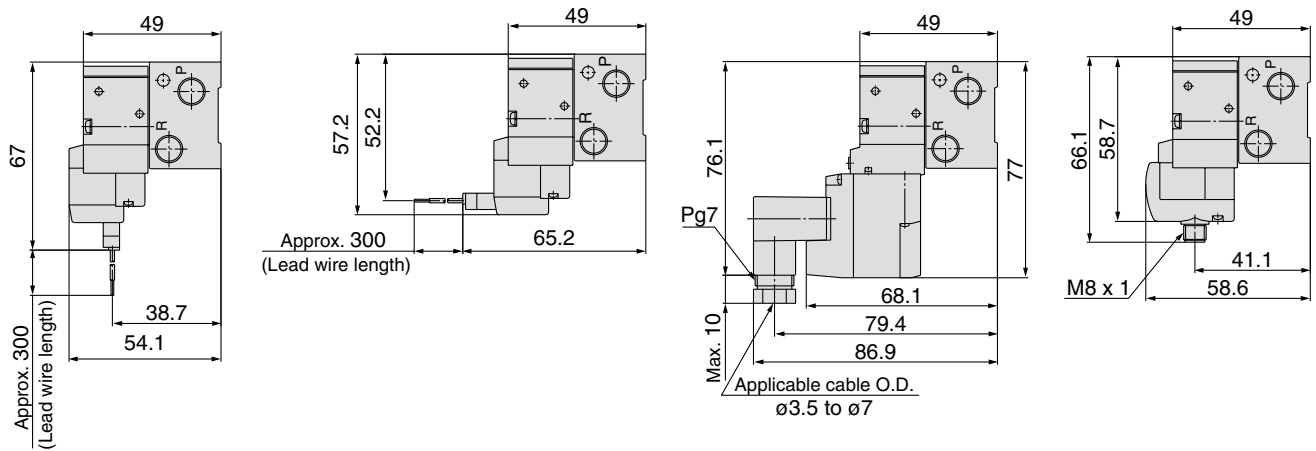

* Refer to back page 10 for dimensions with connector cable.

Station n	Station 2	3	4	5	6	7	8	9	10	11	12	13	14	15	16	17	18	19	Station 20
L1	62	78	94	110	126	142	158	174	190	206	222	238	254	270	286	302	318	334	350
L2	53	69	85	101	117	133	149	165	181	197	213	229	245	261	277	293	309	325	341
L3	47	63	79	95	111	127	143	159	175	191	207	223	239	255	271	287	303	319	335

Series SYJ500

Type 40R Manifold: Bottom Ported (External Pilot Type)/SS3YJ5-40R- Stations -M5, 01□-Q

Grommet (G)

For 1/8

For M5

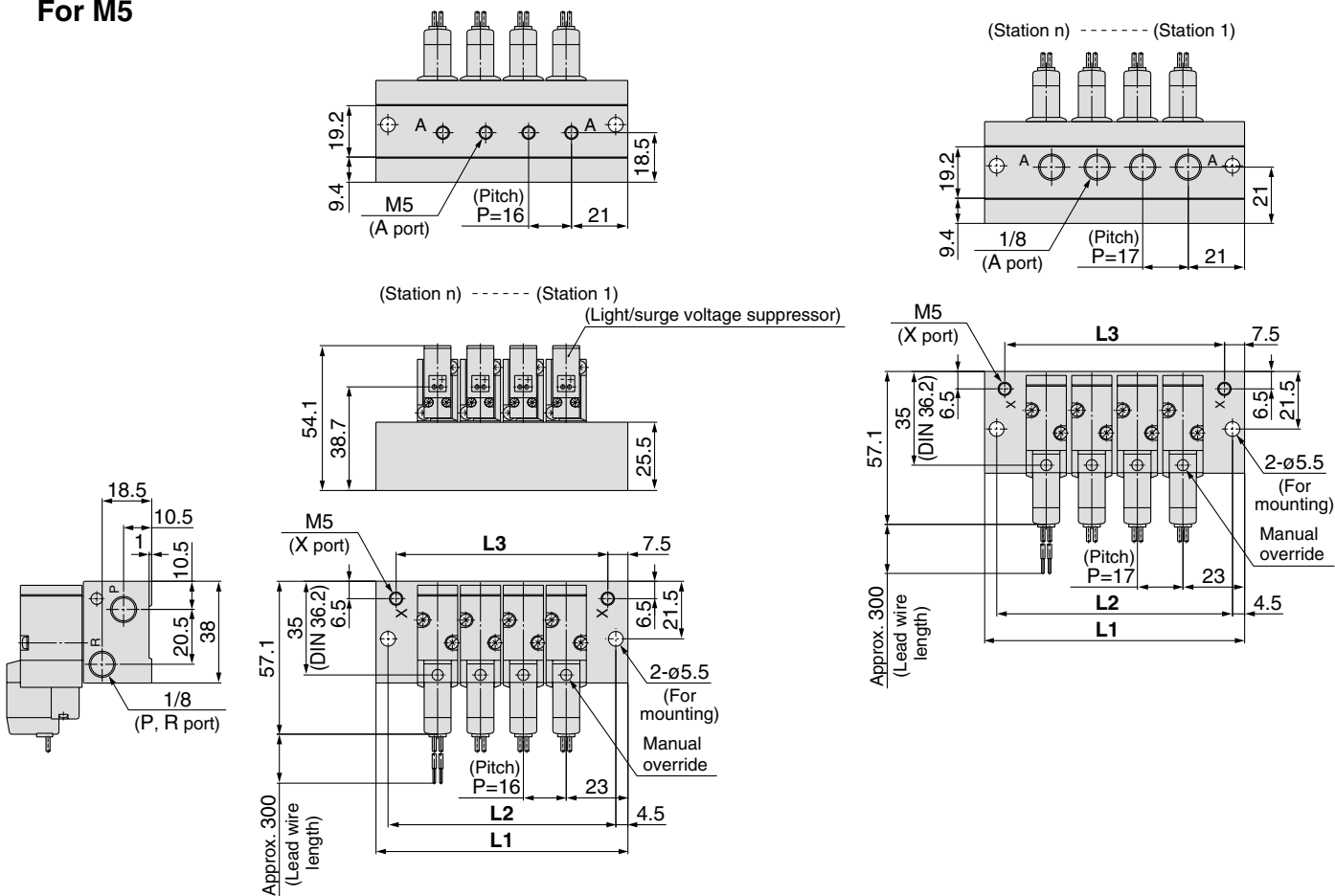

L plug connector (L)

M plug connector (M)

DIN terminal (D)

M8 connector (WO)

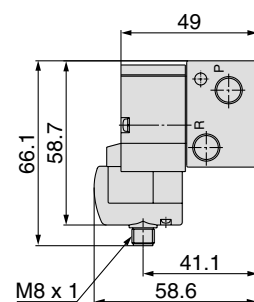
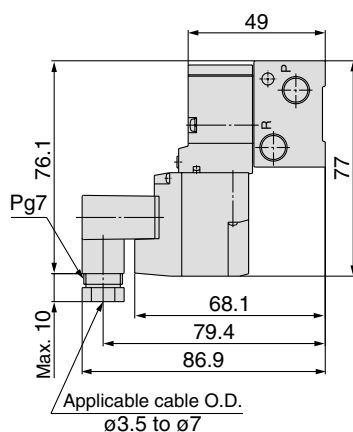
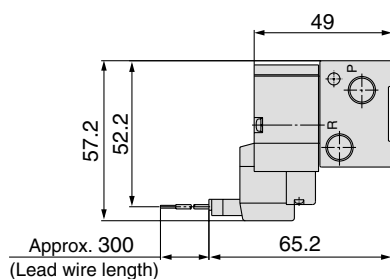
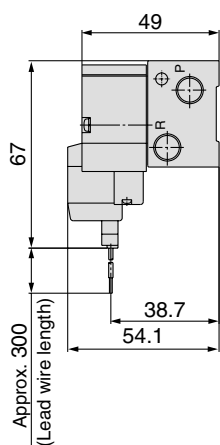

* Refer to back page 10 for dimensions with connector cable.

Port size	Station n	Station 2	3	4	5	6	7	8	9	10	11	12	13	14	15	16	17	18	19	Station 20
M5	L1	62	78	94	110	126	142	158	174	190	206	222	238	254	270	286	302	318	334	350
	L2	53	69	85	101	117	133	149	165	181	197	213	229	245	261	277	293	309	325	341
	L3	47	63	79	95	111	127	143	159	175	191	207	223	239	255	271	287	303	319	335
1/8	L1	63	80	97	114	131	148	165	182	199	216	233	250	267	284	301	318	335	352	369
	L2	54	71	88	105	122	139	156	173	190	207	224	241	258	275	292	309	326	343	360
	L3	48	65	82	99	116	133	150	167	184	201	218	235	252	269	286	303	320	337	354

Type 41R Manifold: Side Ported (External Pilot Type)/SS3YJ5-41R- Stations - C4, N3 C6, N7 □-Q

Grommet (G)

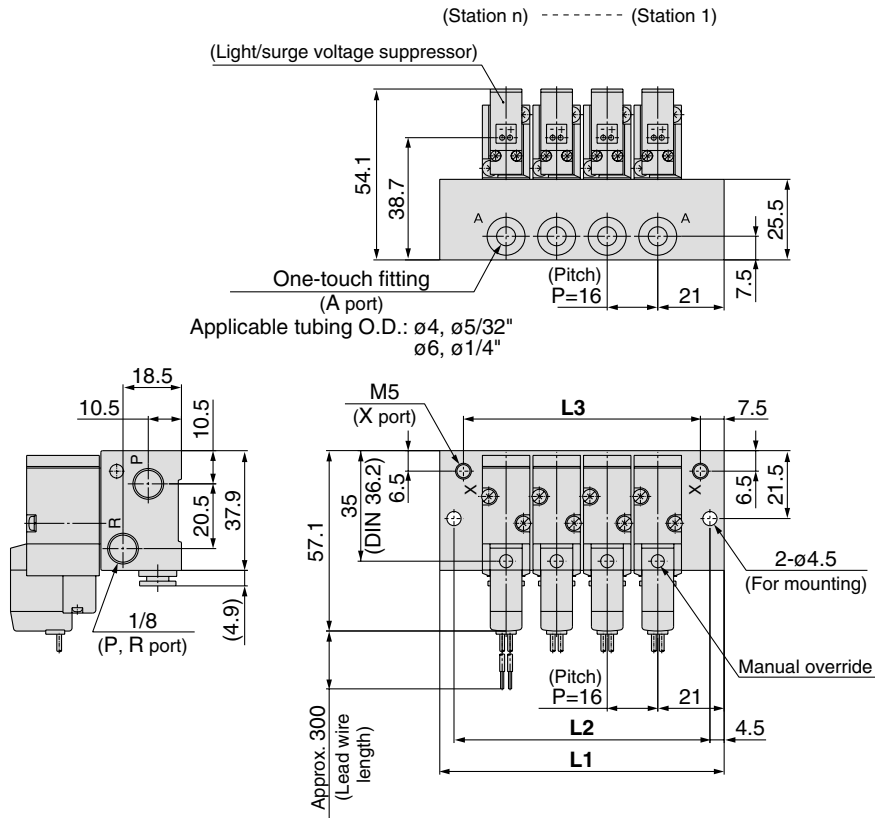

L plug connector (L)

M plug connector (M)

DIN terminal (D)

M8 connector (WO)

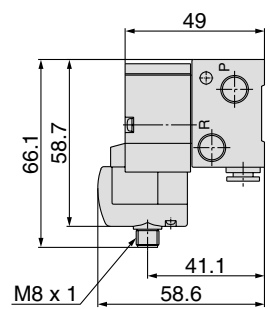
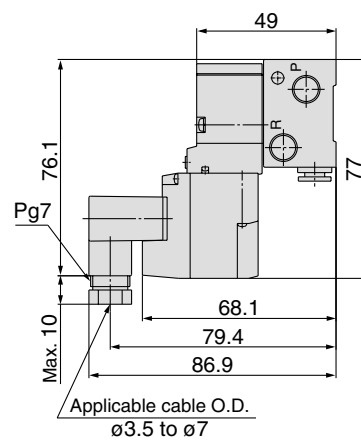
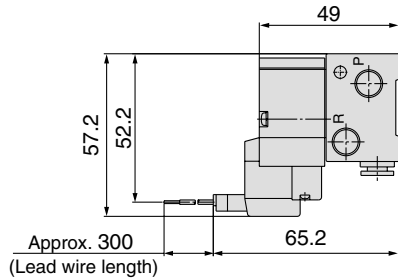
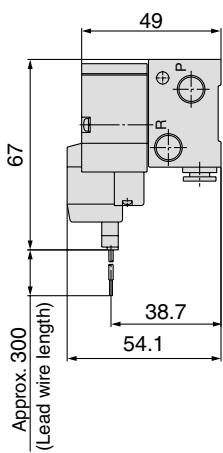

* Refer to back page 10 for dimensions with connector cable.

Port size	Station n	Station 2	3	4	5	6	7	8	9	10	11	12	13	14	15	16	17	18	19	Station 20
One-touch fitting	L1	58	74	90	106	122	138	154	170	186	202	218	234	250	266	282	298	314	330	346
	L2	49	65	81	97	113	129	145	161	177	193	209	225	241	257	273	289	305	321	337
	L3	43	59	75	91	107	123	139	155	171	187	203	219	235	251	267	283	299	315	331

Series SYJ500

Type 41R Manifold: Side Ported (External Pilot Type)/SS3YJ5-41R- Stations -M5, 01□-Q

For M5

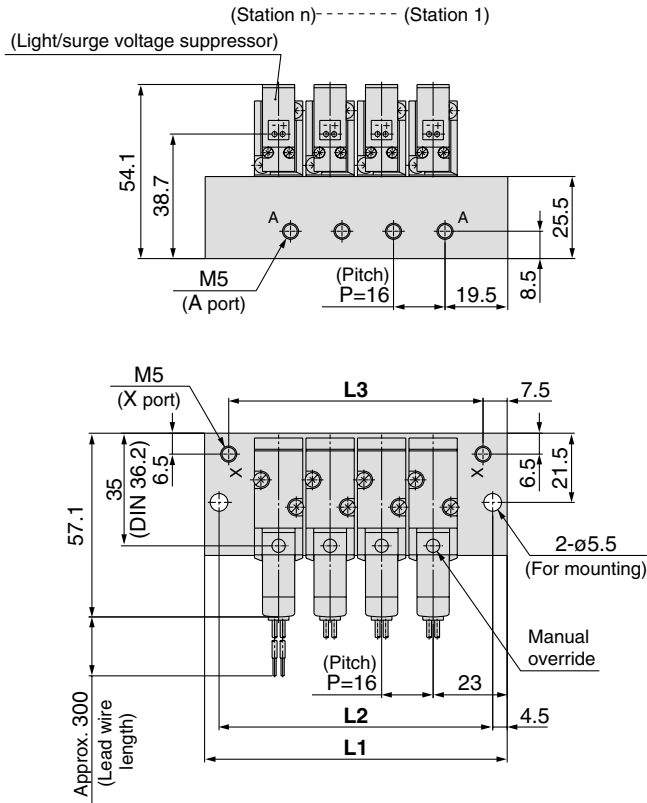

For 1/8

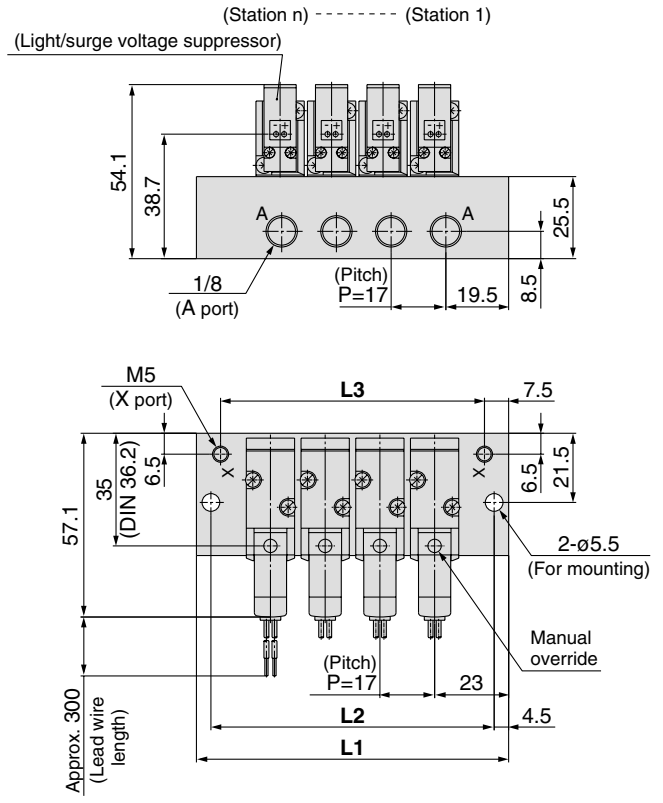

Port size	Station n	Station 2	3	4	5	6	7	8	9	10	11	12	13	14	15	16	17	18	19	Station 20
M5	L1	62	78	94	110	126	142	158	174	190	206	222	238	254	270	286	302	318	334	350
	L2	53	69	85	101	117	133	149	165	181	197	213	229	245	261	277	293	309	325	341
	L3	47	63	79	95	111	127	143	159	175	191	207	223	239	255	271	287	303	319	335
1/8	L1	63	80	97	114	131	148	165	182	199	216	233	250	267	284	301	318	335	352	369
	L2	54	71	88	105	122	139	156	173	190	207	224	241	258	275	292	309	326	343	360
	L3	48	65	82	99	116	133	150	167	184	201	218	235	252	269	286	303	320	337	354

Rubber Seal 3 Port Pilot Solenoid Valve Series SYJ700



Refer to www.smcworld.com for details of products compatible with overseas standards.

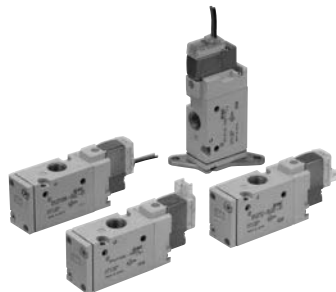

Body ported

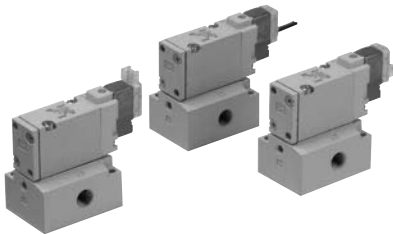

Base mounted

Specifications

Fluid		Air
Operating pressure range (MPa)	Internal pilot	0.15 to 0.7
Ambient and fluid temperature (°C)		-10 to 50 (No freezing. Refer to back page 2.)
Response time ms (at 0.5 MPa) <small>Note 1)</small>		30 or less
Max. operating frequency (Hz)		5
Manual override (Manual operation)		Non-locking push type, push-turn locking slotted type, push-turn locking lever type
Pilot exhaust method		Individual exhaust for the pilot valve, common exhaust for the pilot and main valve
Lubrication		Not required
Mounting orientation		Unrestricted
Shock/Vibration resistance (m/s²) <small>Note 2)</small>		150/30
Enclosure		Dust proof (* DIN terminal, M8 connector: IP65)



* Based on IEC60529

Note 1) Based on dynamic performance test, JIS B 8374-1981. (Coil temperature: 20°C, at rated voltage, without surge voltage suppressor.)

Note 2) Impact resistance: No malfunction occurred when it is tested in the axial direction and at the right angles to the main valve and armature in both energised and de-energised states every once for each condition. (Value in the initial state)

Vibration resistance: No malfunction occurred in one sweep test between 45 and 2000 Hz. Test was performed to axis and right angle directions of the main valve and armature when pilot signal is ON and OFF. (Value in the initial state)

JIS Symbol

Internal pilot

SYJ71₄²

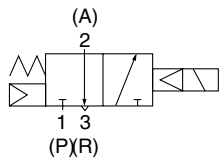

SYJ72₄²

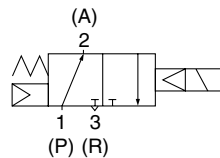

External pilot

SYJ71₄²R

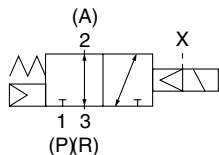

SYJ72₄²R

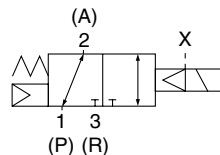

Solenoid Specifications

Electrical entry		Grommet (G), (H), L plug connector (L), M plug connector (M), DIN terminal (D), M8 connector (W)	
		G, H, L, M, W	D
Coil rated voltage (V)	DC	24, 12, 6, 5, 3	24, 12
	AC^{50/60} Hz	-	100, 110, 200, 220
Allowable voltage fluctuation		±10% of rated voltage *	
Power consumption (W)	DC	Standard	0.35 (With light: 0.4 (DIN terminal with light: 0.45))
		With power saving circuit	0.1 (With light only)
Apparent power (VA) *	AC	100 V	- 0.78 (With light: 0.87)
		110 V [115 V]	- 0.86 (With light: 0.97) [0.94 (With light: 1.07)]
		200 V	- 1.15 (With light: 1.30)
		220 V [230 V]	- 1.27 (With light: 1.46) [1.39 (With light: 1.60)]
Surge voltage suppressor		Diode (DIN terminal, varistor when non-polar types)	
Indicator light		LED (Neon light when AC with DIN terminal)	



* In common between 110 VAC and 115 VAC, and between 220 VAC and 230 VAC.

* For 115 VAC and 230 VAC, the allowable voltage is -15% to +5% of rated voltage.

* S, Z and T type (with power saving circuit) should be used within the following allowable voltage fluctuation range due to a voltage drop caused by the internal circuit.

S and Z type: 24 VDC: -7% to +10%

12 VDC: -4% to +10%

T type: 24 VDC: -8% to +10%

12 VDC: -6% to +10%



Made to Order

(For details, refer to pages 57 through to 59.)

Flow Characteristics/Weight

Valve model		Type of actuation	Port size	Flow characteristics								Weight (g) ^{Note)}			
				1→2 (P→A)				2→3 (A→R)				Grommet	L/M plug connector	DIN terminal	M8 connector
				C [dm ³ /(s bar)]	b	Cv	Q _l [l/min(ANR)]*	C [dm ³ /(s bar)]	b	Cv	Q _l [l/min(ANR)]*				
Body ported	SYJ712	N.C.	1/8	2.8	0.43	0.77	779	2.5	0.51	0.76	741	75	76	97	80
	SYJ722	N.O.		2.7	0.38	0.72	724	2.4	0.42	0.69	662				
Base mounted (with sub-plate)	SYJ714	N.C.	1/8	2.9	0.32	0.71	747	2.7	0.34	0.69	705	135 (75)	136 (76)	157 (97)	140 (80)
	SYJ724	N.O.		2.8	0.21	0.70	674	2.3	0.45	0.63	649				
	SYJ714	N.C.	1/4	3.0	0.31	0.74	768	2.6	0.33	0.66	674				
	SYJ724	N.O.		2.7	0.31	0.68	691	2.3	0.48	0.64	665				

Note) Value for DC. Add 3 g for AC. (): Without sub-plate.
 * These values have been calculated according to ISO 6358 and represent the flow rate measured in standard conditions at an upstream pressure of 0.6MPa (relative pressure) and a differential pressure of 0.1MPa.

External Pilot

SYJ700R

Pilot valve pressure is supplied separately from the main valve pressure through the use of a separate supply port. It can be used in the vacuum (up to -100 kPa) or low pressure line with 0.15 MPa or less.

Specifications

Applicable model	Base mounted (SYJ714R, SYJ724R)	
Operating pressure range MPa	Main pressure	-100 kPa to 0.7
	External pilot pressure	0.15 to 0.7

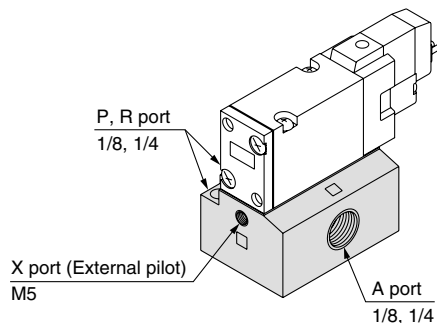

Note 1) For manifold base, refer to page 39.
 Note 2) External pilot type body ported valves (SYJ7□2R) can only be used on the manifold. For body ported models with the external pilot option, please refer to page 59.

How to Order

Rated voltage

DC

5	24 VDC
6	12 VDC
V	6 VDC
S	5 VDC
R	3 VDC

* DC specifications of type D and DO is only available with 12 and 24 VDC.

AC (50/60 Hz)

1	100 VAC
2	200 VAC
3	110 VAC [115 VAC]
4	220 VAC [230 VAC]

* AC specification is only available with D, DO type.

Light/surge voltage suppressor

Electrical entry for G, H, L, M and W

-	Without light/surge voltage suppressor
S	With surge voltage suppressor
Z	With light/surge voltage suppressor
R	With surge voltage suppressor (Non-polar type)
U	With light/surge voltage suppressor (Non-polar type)

* Power saving circuit is only available in the "Z" type.

Electrical entry for D

-	Without light/surge voltage suppressor
S	With surge voltage suppressor (Non-polar type)
Z	With light/surge voltage suppressor (Non-polar type)

* DOZ is not available.
* For AC voltage valves there is no "S" option. It is already built-in to the rectifier circuit.

Type of actuation

1	Normally closed
2	Normally open

3 port

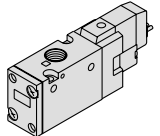

(For manifold type 20, 21R)

Thread type

-	Rc
F	G
N	NPT
T	NPTF

Bracket

-: Without bracket
F: With bracket

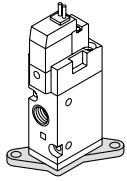

* Bracket is mounted.
* External pilot type is not available.

Body ported SYJ7 1 2 □ □ 5 M □ □ 01 □ □ Q

Base mounted SYJ7 1 4 □ □ 5 M □ □ 01 □ □ Q

Coil specifications

-	Standard
T	With power saving circuit (24, 12 VDC only)

* Power saving circuit is not available in the case of D, DO, W□ type.

Manual override

-: Non-locking push type

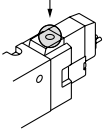

D: Push-turn locking slotted type

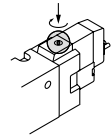

E: Push-turn locking lever type

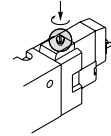

Thread type

-	Rc
F	G
N	NPT
T	NPTF

Port size

-: Without sub-plate 01: 1/8 port With sub-plate 02: 1/4 port With sub-plate

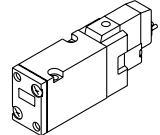
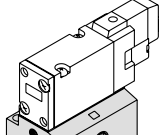
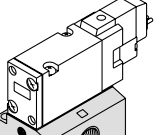
(With gasket and screws)

Body option

-: Individual pilot exhaust type

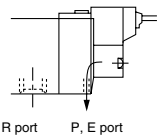

R port P, E port

M: Common exhaust for the pilot and main valve

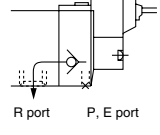

R port P, E port

R: External pilot type*



* SYJ7□2R is only for manifold use.

Electrical entry

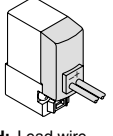
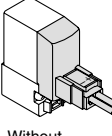
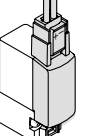
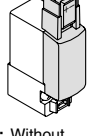
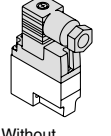
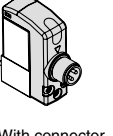
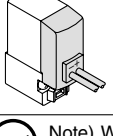
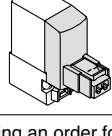
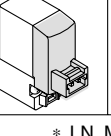
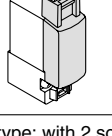
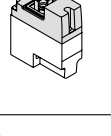
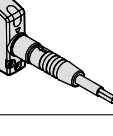
24, 12, 6, 5, 3 VDC				24, 12 VDC/ 100, 110, 200, 220 VAC	24, 12, 6, 5, 3 VDC
Grommet	L plug connector	M plug connector		DIN terminal	M8 connector *
G: Lead wire length 300 mm	L: With lead wire (Length 300 mm)	M: With lead wire (Length 300 mm)	MN: Without lead wire	D: With connector	WO: Without connector cable
					
	LN: Without lead wire	LO: Without connector	MO: Without connector	DO: Without connector	W□: With connector cable Note 1)
					

Note) When placing an order for body ported solenoid valve as a single unit, mounting bolt for manifold and gasket are not attached. Order them separately, if necessary. (For details, refer to catalogue on page 40.)

* LN, MN type: with 2 sockets.
* DIN terminal type "Y" which conforms to EN-175301-803C (former DIN43650C) is also available. For details, refer to page 57.
* For connector cable of M8 connector, refer to back page 9.
* Connector M8 type "WA" conforming to IEC 60947-5-2 standard, is also available. For details, see page 58.
Note 1) Enter the cable length symbols in □. Please be sure to fill in the blank referring to back page 10.

Construction

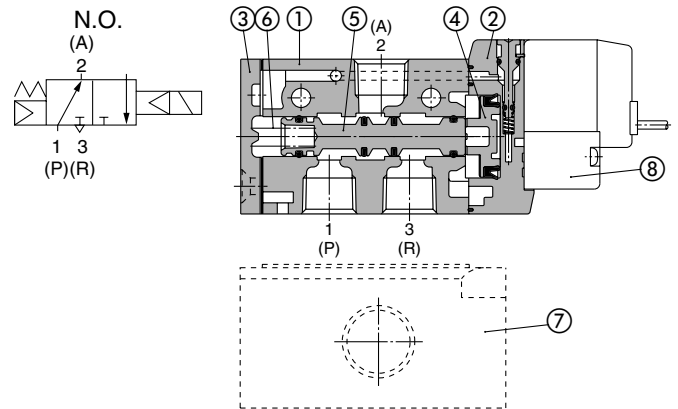
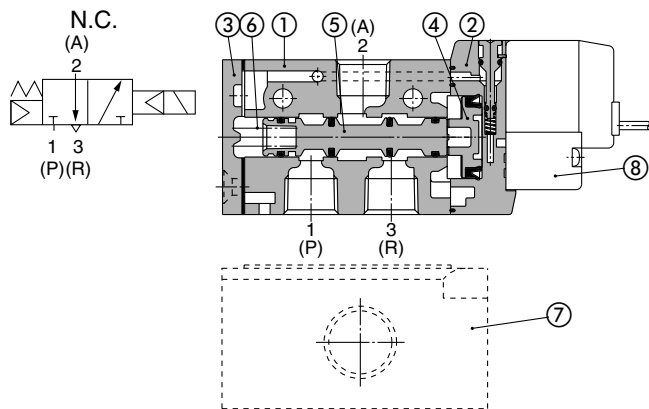

Component Parts

No.	Description	Material	Note
1	Body	Aluminum die-casted	White
2	Piston plate	Resin	White
3	End cover	Aluminum die-casted	White
4	Piston	Resin	—
5	Spool valve assembly	—	—
6	Spool spring	Stainless steel	—

Replacement Parts

No.	Description	No.	Note
7	Sub-plate	SYJ700-9-1-Q	1/8
		SYJ700-9-2-Q	1/4
8	Pilot valve	V111(T)-□□□□	
—	Bracket assembly	SYJ700-19-1A	

How to Order Pilot Valve Assembly

V111 □ — 5 G □

Coil specifications

-	Standard
T	With power saving circuit (24, 12 VDC only)

* Power saving circuit is not available in the case of W□ type.

Rated voltage

5	24 VDC
6	12 VDC
V	6 VDC
S	5 VDC
R	3 VDC

Light/surge voltage suppressor

-	Without light/surge voltage suppressor
S	With surge voltage suppressor
Z	With light/surge voltage suppressor
R	With surge voltage suppressor (Non-polar type)
U	With light/surge voltage suppressor (Non-polar type)

* Power saving circuit is only available in the "Z" type.

Electrical entry

G	Grommet, 300 mm lead wire
H	Grommet, 600 mm lead wire
L	L plug connector
LN	L plug connector With lead wire
LO	L plug connector Without lead wire
M	M plug connector
MN	M plug connector With lead wire
MO	M plug connector Without lead wire
WO	M8 connector Without connector cable
W□	M8 connector With connector cable ^{Note 1)}

* For connector cable of M8 connector, refer to back page 9.

How to Order Connector Assembly for L/M Plug Connector

For DC: SY100-30-4A-□

Without lead wire: SY100-30-A
(with connector and 2 of sockets only)

Lead wire length

-	300 mm
6	600 mm
10	1000 mm
15	1500 mm
20	2000 mm
25	2500 mm
30	3000 mm
50	5000 mm

Note 1) Enter the cable length symbols in □. Please be sure to fill in the blank referring to back page 10.

How to Order M8 Connector Cable

V115 — 5 D □

Rated voltage

5	24 VDC
6	12 VDC
1	100 VAC 50/60 Hz
2	200 VAC 50/60 Hz
3	110 VAC 50/60 Hz [115 VAC 50/60 Hz]
4	220 VAC 50/60 Hz [230 VAC 50/60 Hz]

* DC specifications of type D and DO is only available with 12 and 24 VDC.

* Power saving circuit is not available in the case of D or DO type.

Light/surge voltage suppressor

-	Without light/surge voltage suppressor
S	With surge voltage suppressor (Non-polar type)
Z	With light/surge voltage suppressor (Non-polar type)

* DOZ is not available.
* For AC voltage valves there is no "S" option. It is already built-in to the rectifier circuit.

Electrical entry

D	DIN terminal	With connector
DO	DIN terminal	Without connector

* Do not replace V111 (G, H, L, M, W) to V115 (DIN terminal) and vice versa when replacing pilot valve assembly only.

V100-49-1-□

Cable length

1	300 mm
2	500 mm
3	1000 mm
4	2000 mm
7	5000 mm

Series SYJ700

Body Ported

Grommet (G), (H): SYJ7□2-□^G□□-01□-Q

With bracket:

SYJ7□2-□^G□□-01□-F-Q

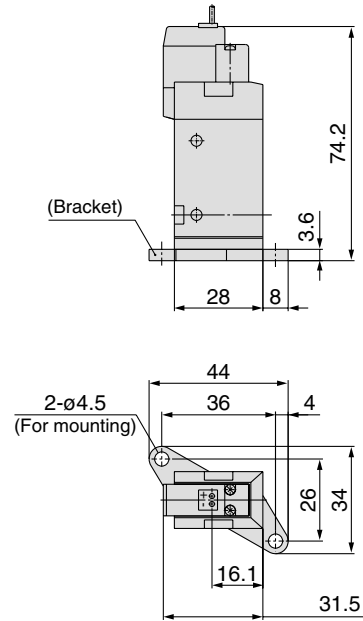
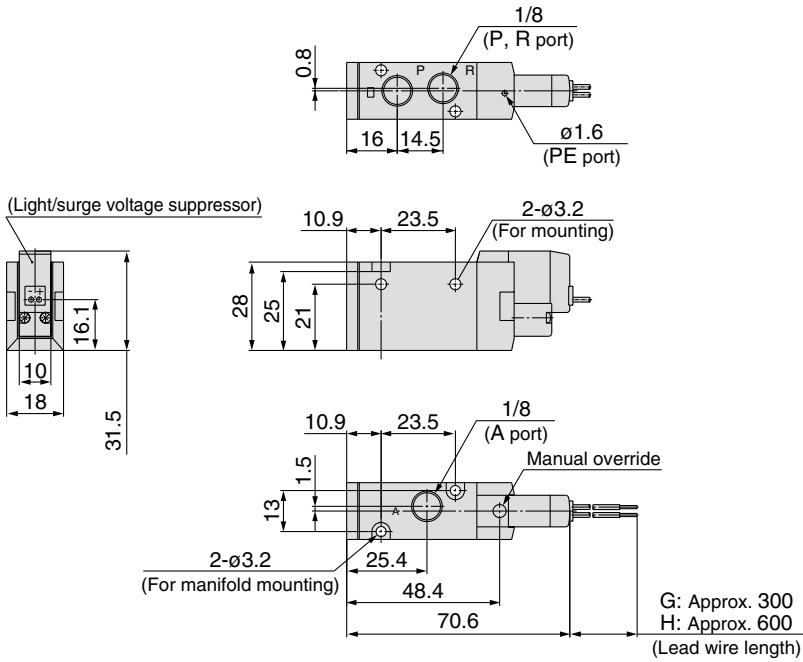

L plug connector (L):
SYJ7□2-□L□□-01□ (-F)-Q

M plug connector (M):
SYJ7□2-□M□□-01□ (-F)-Q

DIN terminal (D):
SYJ7□2-□D□□-01□ (-F)-Q

M8 connector (WO):
SYJ7□2-□WO□□-01□ (-F)-Q

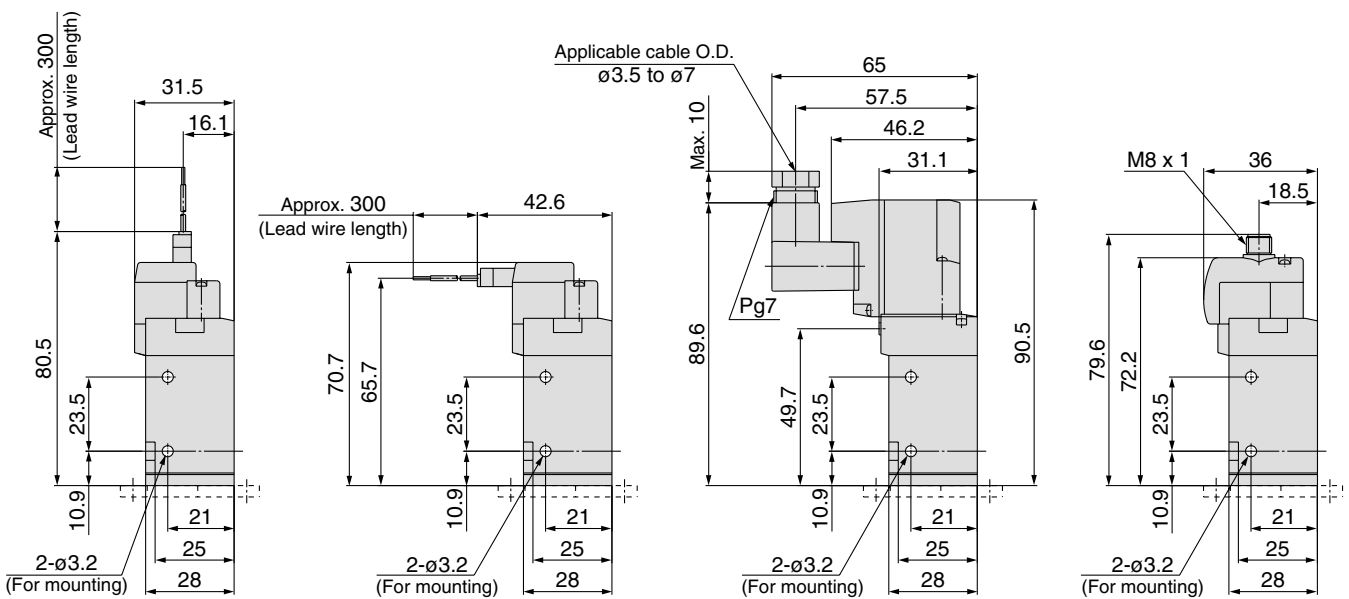

* Refer to back page 10 for dimensions with connector cable.

Base Mounted (With Sub-plate)

Grommet (G), (H): SYJ7□4-□^G□□-⁰¹□□-Q

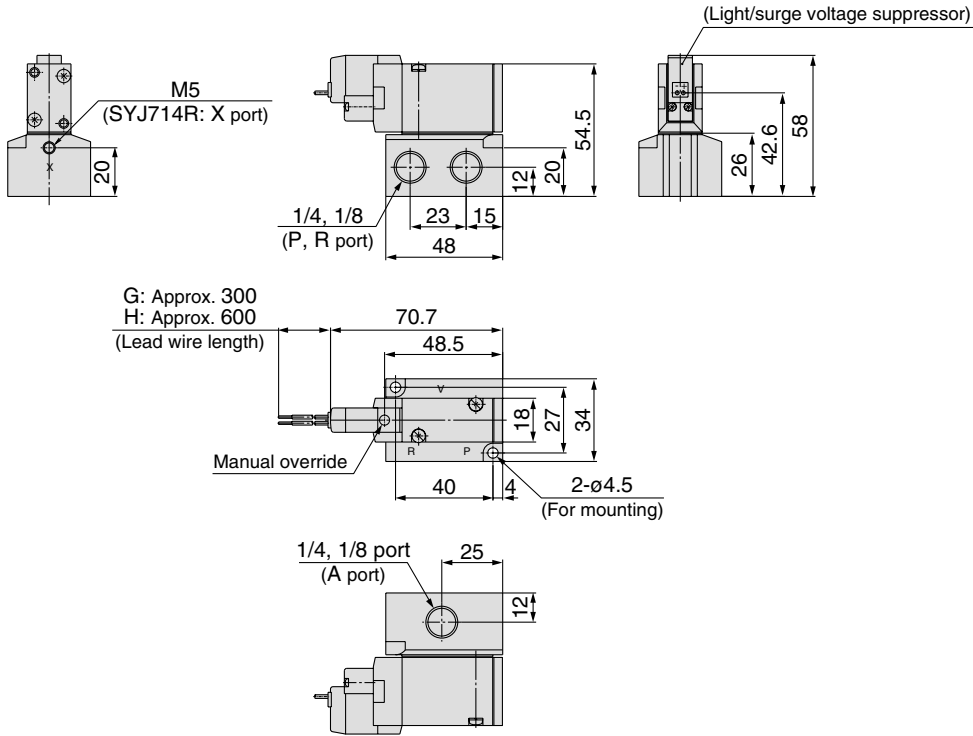

L plug connector (L):
SYJ7□4-□L□□-⁰¹□□-Q

M plug connector (M):
SYJ7□4-□M□□-⁰¹□□-Q

DIN terminal (D):
SYJ7□4-□D□□-⁰¹□□-Q

M8 connector (WO):
SYJ7□4-□WO□□-⁰¹□□-Q

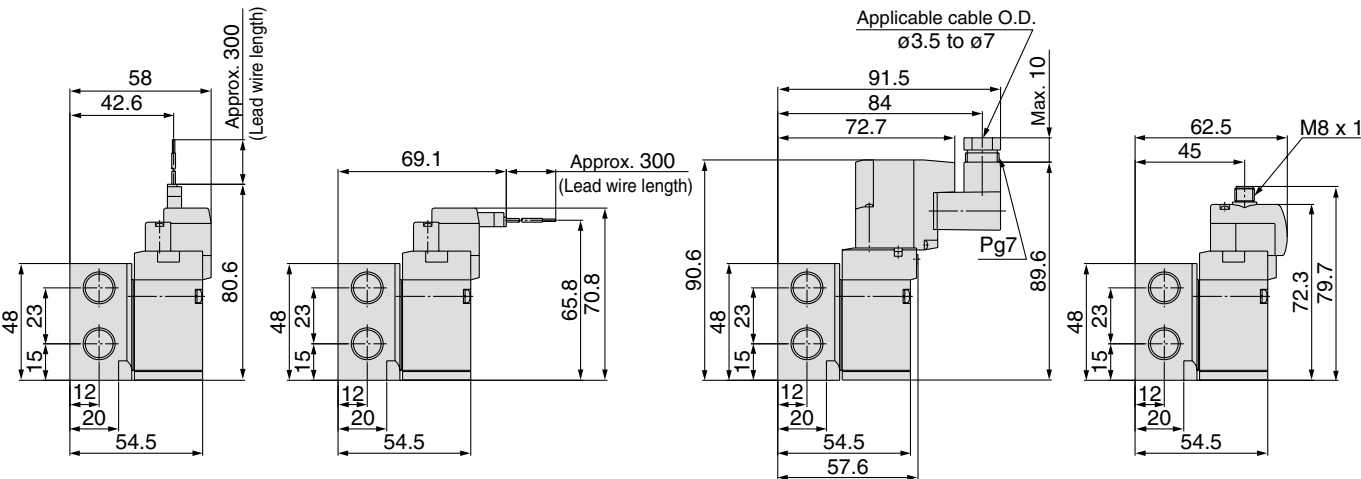

* Refer to back page 10 for dimensions with connector cable.

Series SYJ700 Manifold Specifications

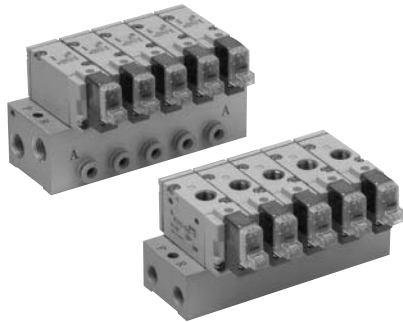

Manifold Specifications

Model	For internal pilot	Type 20	Type 21	Type 40	Type 41	Type 42
	For external pilot	—	Type 21R	—	Type 41R	Type 42R
Manifold type		Single base/B mount				
P (SUP), R (EXH)		Common SUP, common EXH				
Valve stations		2 to 20 stations				
A port Porting specifications	Location	Valve	Valve	Base	Base	Base
	Direction	Top	Top	Bottom	Bottom	Side
Port size	P, R port	1/8	1/4	1/8	1/4	1/4
	A port	1/8	1/8	1/8	1/8	1/8 C6 (ø6 one-touch fitting) C8 (ø8 one-touch fitting)
	X port ^{Note)}	—	M5	—	M5	M5

Note) Only for external pilot

Flow Characteristics

Manifold			Port size		Flow characteristics							
					1→2 (P→A)				2→3 (A→R)			
			1(P), 3(R) port	2(A) port	C [dm ³ /(sbar)]	b	Cv	Q[l/min(ANR)]*	C [dm ³ /(sbar)]	b	Cv	Q[l/min(ANR)]*
Body ported for internal pilot	Type SS3YJ7-20	SYJ7□2	1/8	1/8	2.2	0.34	0.55	574	2.3	0.27	0.59	574
	Type SS3YJ7-21		1/4	1/8	2.2	0.39	0.59	594	2.4	0.32	0.62	618
Base mounted for internal pilot	Type SS3YJ7-40	SYJ7□4	1/8	1/8	2.1	0.35	0.59	552	2.3	0.27	0.54	574
	Type SS3YJ7-41		1/4	1/8	2.2	0.35	0.59	578	2.4	0.36	0.66	635
	Type SS3YJ7-42-01		1/4	1/8	2.0	0.27	0.47	499	2.2	0.32	0.56	567
	Type SS3YJ7-42-C6		1/4	C6	1.6	0.32	0.39	412	2.2	0.27	0.54	549
Body ported for external pilot	Type SS3YJ7-21R	SYJ7□2R	1/4	1/8	2.2	0.34	0.55	574	2.4	0.32	0.62	618
	Type SS3YJ7-41R	SYJ7□4R	1/4	1/8	2.2	0.35	0.59	578	2.4	0.36	0.66	635
Base mounted for external pilot	Type SS3YJ7-42R-01		1/4	1/8	2.0	0.27	0.47	499	2.2	0.32	0.56	567
	Type SS3YJ7-42R-C6		1/4	C6	1.6	0.32	0.39	412	2.2	0.27	0.54	549
	Type SS3YJ7-42R-C8		1/4	C8	2.1	0.24	0.51	515	2.3	0.31	0.59	589

Note) Value at manifold base mounted, 2 position single operating.
*These values have been calculated according to ISO 6358 and represent the flow rate measured in standard conditions at an upstream pressure of 0.6MPa (relative pressure) and a differential pressure of 0.1MPa.

How to Order Manifold (Example)

Instruct by specifying the valves and blanking plate assembly to be mounted on the manifold along with the manifold base model no.

(Example)

SS3YJ7-20-03-Q1 set (manifold base) **SS3YJ7-42R-03-01-Q**1 set (manifold base)

* **SYJ712-5LZ-01-Q** 2 sets (valve) * **SYJ714R-5G-Q** 2 sets (valve)

* **SYJ700-10-1A-Q** 1 set (blanking plate assembly)* **SYJ700-10-2A-Q**1 set (blanking plate assembly)

↳ The asterisk denotes the symbol for assembly. Prefix it to the part nos. of the solenoid valve, etc.

Combinations of Solenoid Valve, Manifold Gasket and Manifold Base

Body ported (Type SYJ7□2-Q)

Base mounted (Type SYJ7□4-Q)

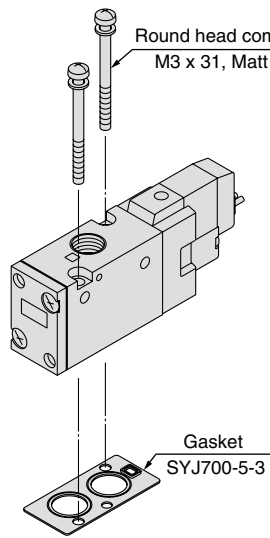

Applicable base
 SS3YJ7-20-Q
 SS3YJ7-21-Q
 SS3YJ7-21R-Q

Manifold base

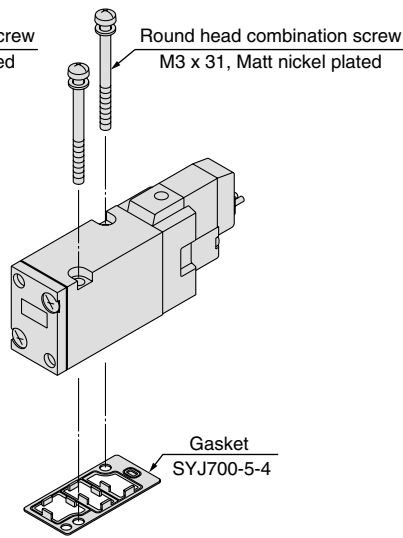

Applicable base Sub-plate
 SS3YJ7-40-Q
 SS3YJ7-41-Q
 SS3YJ7-42-Q
 SS3YJ7-41R-Q
 SS3YJ7-42R-Q

Manifold base

Blanking Plate Assembly

Model no.: SYJ700-10-2A-1-Q

(In common for body ported type and base mounted type)

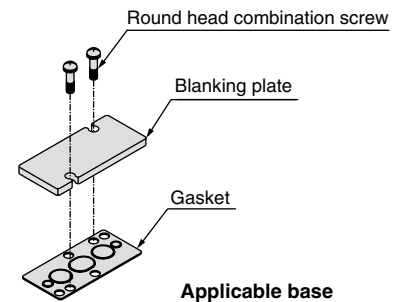

Applicable base
 SS3YJ7-20-Q
 SS3YJ7-21-Q
 SS3YJ7-21R-Q

Manifold base

Model no.: SYJ700-10-2A-2-Q

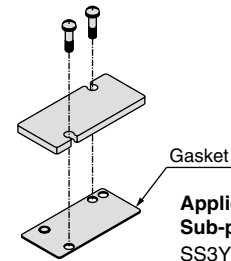

Applicable base Sub-plate:
 SS3YJ7-40-Q
 SS3YJ7-41-Q
 SS3YJ7-42-Q
 SS3YJ7-41R-Q
 SS3YJ7-42R-Q

Manifold base

⚠ Caution

Mounting screw tightening torques

M3: 0.8 N·m

Use caution to the assembly orientation for solenoid valves, gasket, and optional parts.

Series SYJ700

Manifold for Internal Pilot Type

Type 20/Type 21

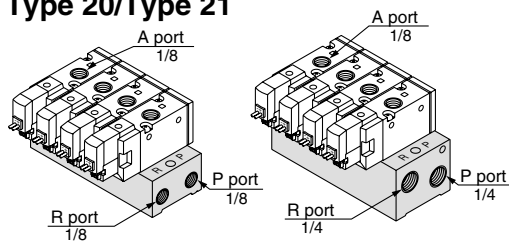

How to Order

SS3YJ7-20-05-□-Q

Manifold type	
20	Type 20
21	Type 21

Stations	
02	2 stations
:	:
20	20 stations

P, R port thread type	
-	Rc
00F	G
00N	NPT
00T	NPTF

Applicable solenoid valve
 SYJ712-□□□□-01-Q
 SYJ712M-□□□□-01-Q
 SYJ722-□□□□-01-Q
 SYJ722M-□□□□-01-Q

Applicable blanking plate assembly
 SYJ700-10-2A-1-Q

Note) If there are more than 6 stations for type 20, or more than 9 stations for 21 type, supply air to both sides of P port and exhaust air from both sides of R port.

Type 40/Type 41

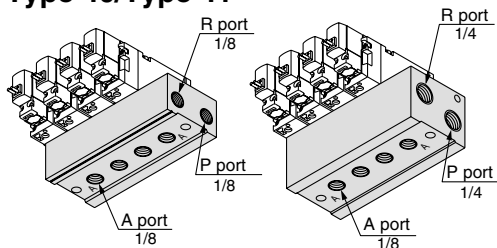

How to Order

SS3YJ7-40-05-01-□-Q

Manifold type	
40	Type 40
41	Type 41

Stations	
02	2 stations
:	:
20	20 stations

A port size	
01	1/8

P, R port thread type	
-	Rc
F	G
N	NPT
T	NPTF

Applicable solenoid valve
 SYJ714-□□□□-Q
 SYJ714M-□□□□-Q
 SYJ724-□□□□-Q
 SYJ724M-□□□□-Q

Applicable blanking plate assembly
 SYJ700-10-2A-2-Q

Note) If there are more than 6 stations for type 40, or more than 9 stations for 41 type, supply air to both sides of P port and exhaust air from both sides of R port.

Type 42

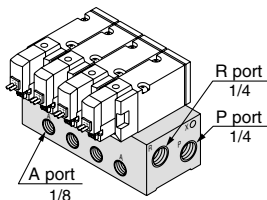

How to Order

SS3YJ7-42-05-C6-□-Q

Stations	
02	2 stations
:	:
20	20 stations

A port size	
01	1/8
C6	ø6 one-touch fitting
C8	ø8 one-touch fitting
N7	ø1/4" one-touch fitting
N9	ø5/16" one-touch fitting

P, R port thread type	
-	Rc
F	G
N	NPT
T	NPTF

Applicable solenoid valve
 SYJ714-□□□□-Q
 SYJ714M-□□□□-Q
 SYJ724-□□□□-Q
 SYJ724M-□□□□-Q

Applicable blanking plate assembly
 SYJ700-10-2A-2-Q

Note) For more than 9 stations, supply air to both sides of P port and exhaust air from both sides of R port.

Manifold for External Pilot Type

Pilot valve pressure is supplied separately from the main valve pressure through the use of a separate supply port. It can be used in the vacuum (up to -100 kPa) or low pressure line with 0.15 MPa or less.

Type 21R

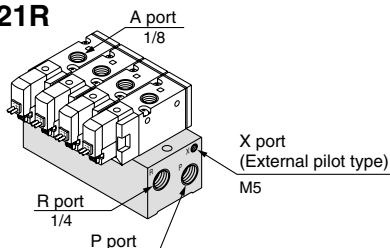

How to Order

SS3YJ7-21R-05-□-Q

Stations	
02	2 stations
:	:
20	20 stations

P, R port thread type	
-	Rc
00F	G
00N	NPT
00T	NPTF

Applicable solenoid valve
 SYJ712R-□□□□-01-Q
 SYJ722R-□□□□-01-Q

Applicable blanking plate assembly
 SYJ700-10-2A-1-Q

Note) For more than 9 stations, supply/exhaust air to/from both sides of P and R port.

Type 41R

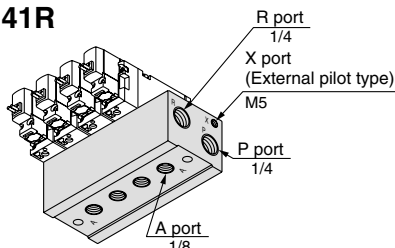

How to Order

SS3YJ7-41R-05-01-□-Q

Stations	
02	2 stations
:	:
20	20 stations

A port size	
01	1/8

P, R port thread type	
-	Rc
F	G
N	NPT
T	NPTF

Applicable solenoid valve
 SYJ714R-□□□□-Q
 SYJ724R-□□□□-Q

Applicable blanking plate assembly
 SYJ700-10-2A-2-Q

Note) For more than 9 stations, supply/exhaust air to/from both sides of P and R port.

Type 42R

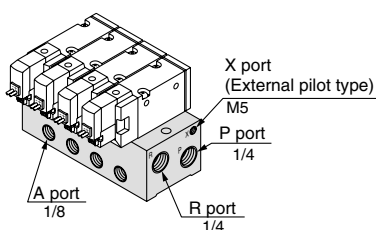

How to Order

SS3YJ7-42R-05-01-□-Q

Stations	
02	2 stations
:	:
20	20 stations

A port size	
01	1/8
C6	ø6 one-touch fitting
C8	ø8 one-touch fitting
N7	ø1/4" one-touch fitting
N9	ø5/16" one-touch fitting

P, R port thread type	
-	Rc
F	G
N	NPT
T	NPTF

Applicable solenoid valve
 SYJ714R-□□□□-Q
 SYJ724R-□□□□-Q

Applicable blanking plate assembly
 SYJ700-10-2A-2-Q

Note) For more than 9 stations, supply/exhaust air to/from both sides of P and R port.

Type 20 Manifold: Top Ported/SS3YJ7-20- Stations (-00□)-Q

Grommet (G)

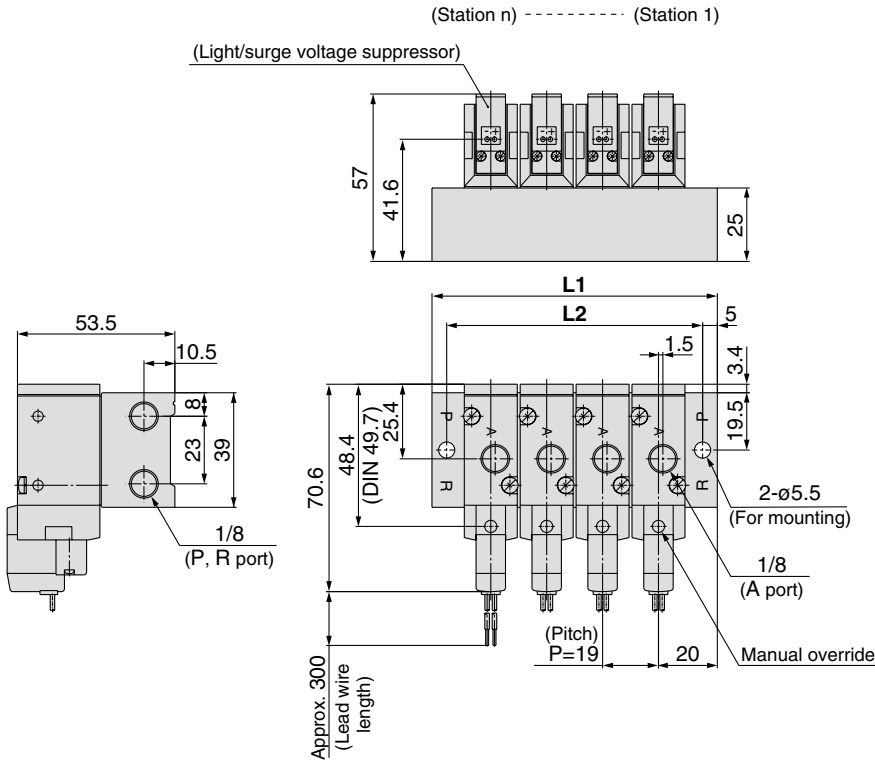

L plug connector (L)

M plug connector (M)

DIN terminal (D)

M8 connector (WO)

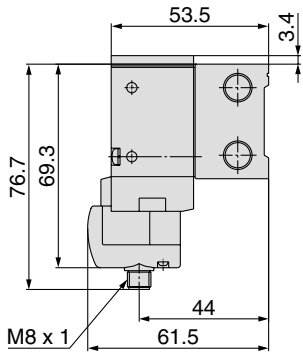
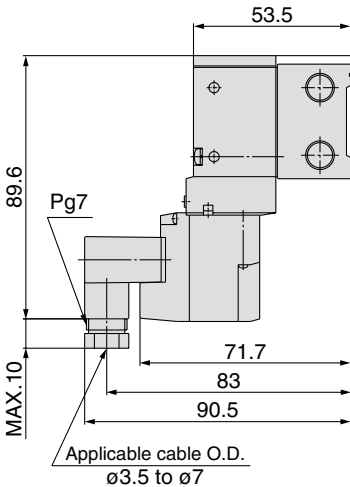
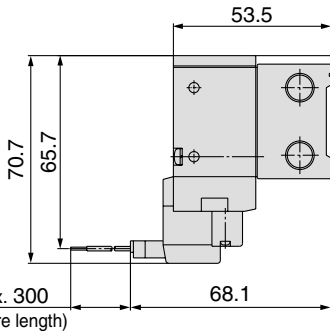
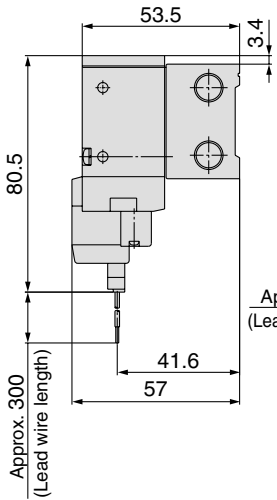

* Refer to back page 10 for dimensions with connector cable.

Station n	Station 2	3	4	5	6	7	8	9	10	11	12	13	14	15	16	17	18	19	Station 20
L1	59	78	97	116	135	154	173	192	211	230	249	268	287	306	325	344	363	382	401
L2	49	68	87	106	125	144	163	182	201	220	239	258	277	296	315	334	353	372	391

Series SYJ700

Type 21 Manifold: Top Ported/SS3YJ7-21- Stations (-00□)-Q

Grommet (G)

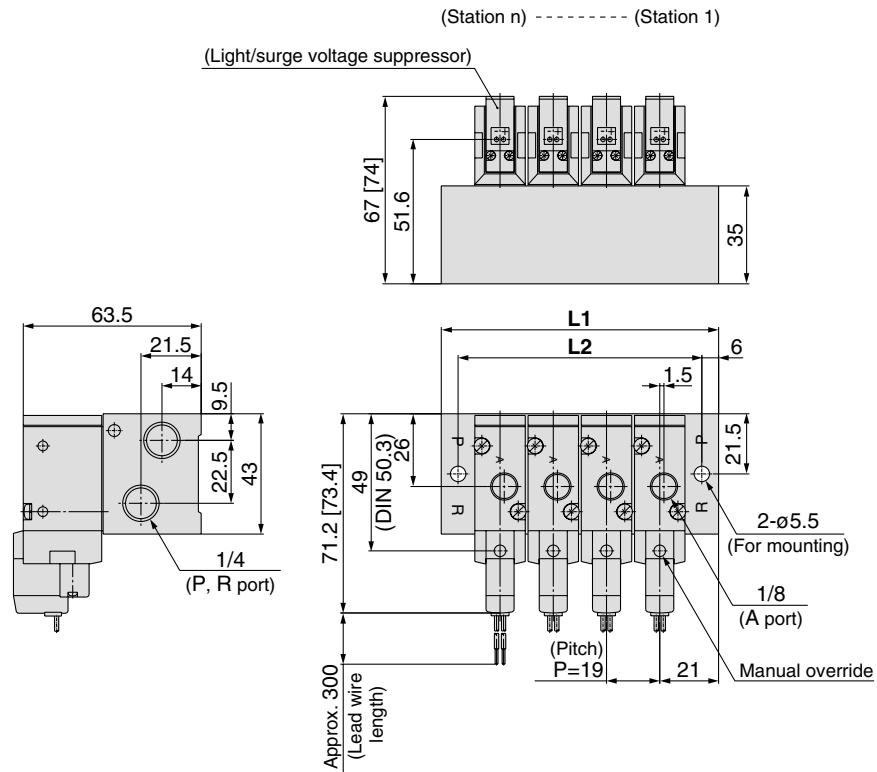

L plug connector (L)

M plug connector (M)

DIN terminal (D)

M8 connector (WO)

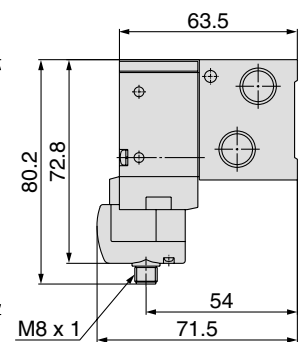
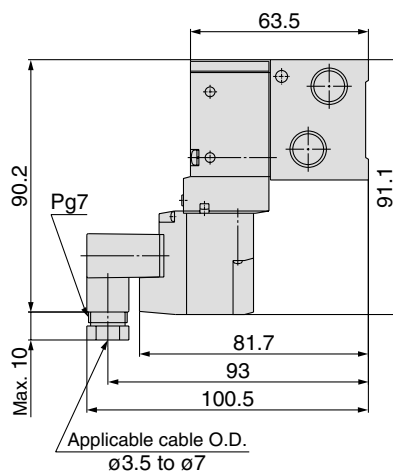
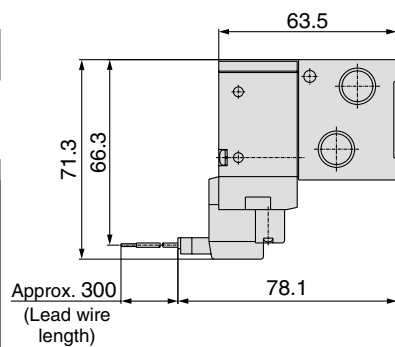
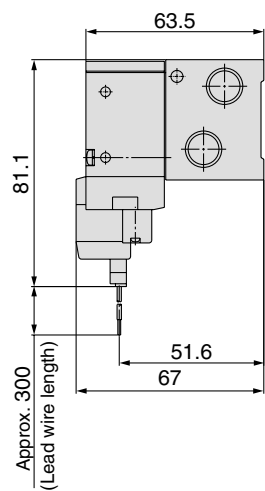

* Refer to back page 10 for dimensions with connector cable.

Station n	Station 2	3	4	5	6	7	8	9	10	11	12	13	14	15	16	17	18	19	Station 20
L1	61	80	99	118	137	156	175	194	213	232	251	270	289	308	327	346	365	384	403
L2	49	68	87	106	125	144	163	182	201	220	239	258	277	296	315	334	353	372	391

Type 40 Manifold: Bottom Ported/SS3YJ7-40- Stations -01□-Q

Grommet (G)

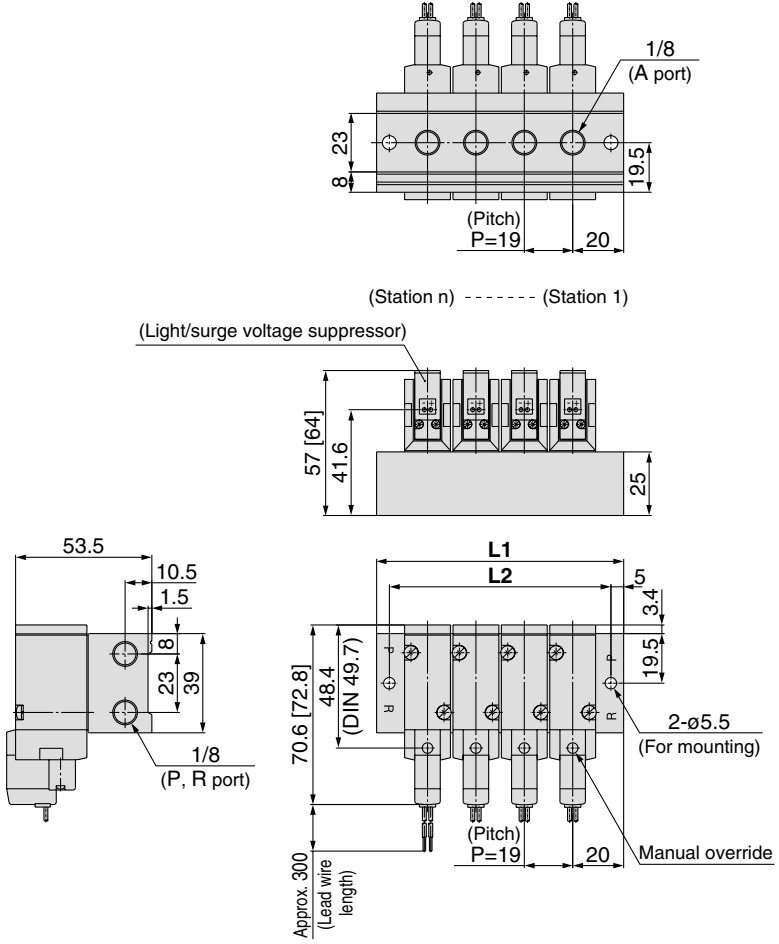

L plug connector (L)

M plug connector (M)

DIN terminal (D)

M8 connector (WO)

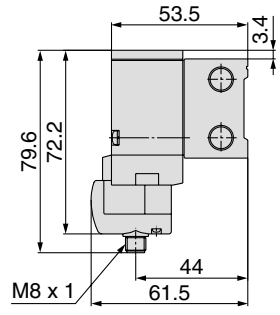
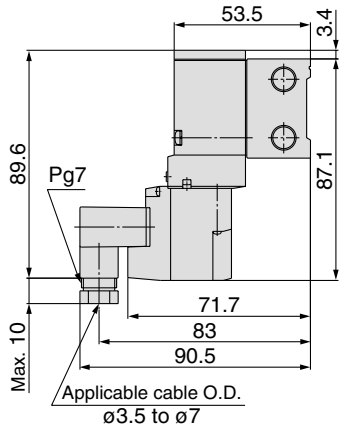
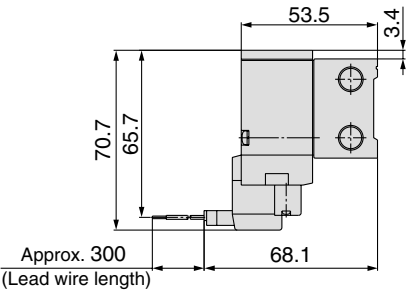
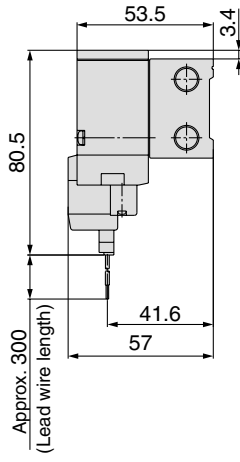

* Refer to back page 10 for dimensions with connector cable.

Station n	Station 2	3	4	5	6	7	8	9	10	11	12	13	14	15	16	17	18	19	Station 20
L1	59	78	97	116	135	154	173	192	211	230	249	268	287	306	325	344	363	382	401
L2	49	68	87	106	125	144	163	182	201	220	239	258	277	296	315	334	353	372	391

Series SYJ700

Type 42 Manifold: Side Ported/SS3YJ7-42- Stations -01, $\begin{matrix} C6 & N7 \\ C8 & N9 \end{matrix} \square -Q$

Grommet (G)

For $\begin{matrix} C6 & N7 \\ C8 & N9 \end{matrix} \square$ (Built-in one-touch fitting)

For 1/8

(Light/surge voltage suppressor)

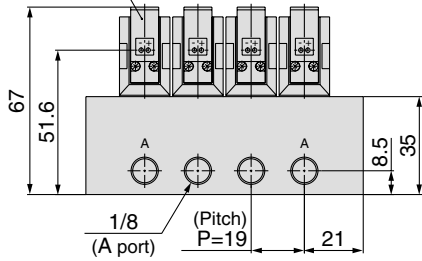

(Station n) ----- (Station 1)

(Light/surge voltage suppressor)

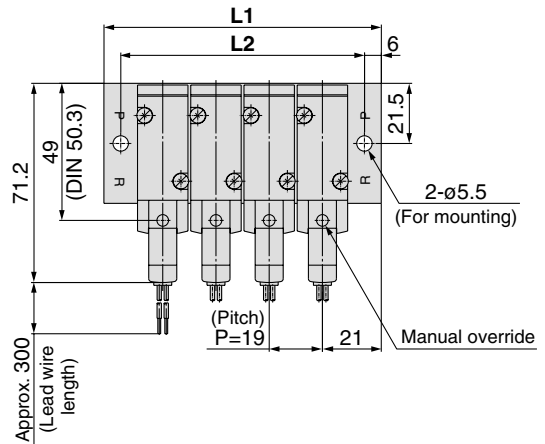
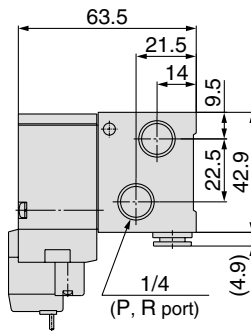
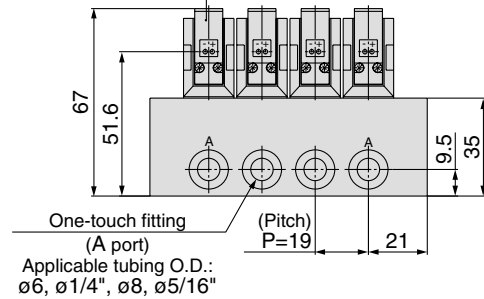

L plug connector (L)

M plug connector (M)

DIN terminal (D)

M8 connector (WO)

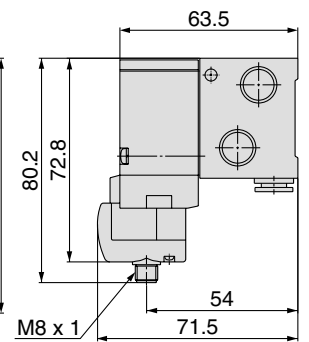
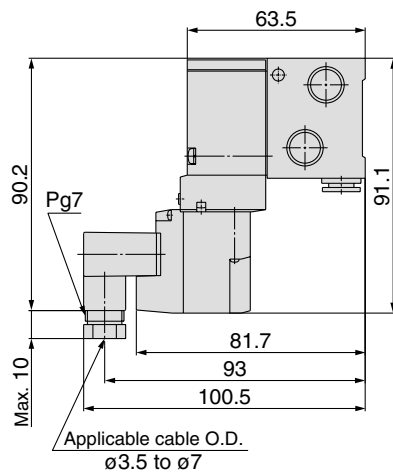
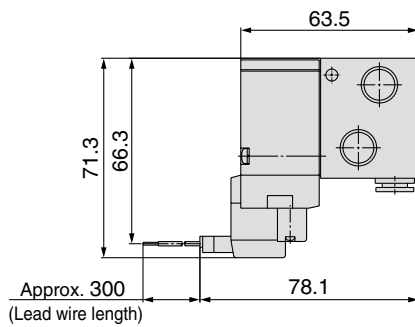
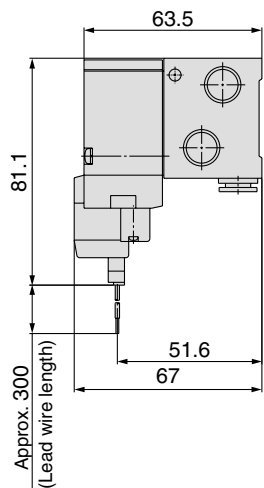

* Refer to back page 10 for dimensions with connector cable.

Station n	Station 2	3	4	5	6	7	8	9	10	11	12	13	14	15	16	17	18	19	Station 20
L1	61	80	99	118	137	156	175	194	213	232	251	270	289	308	327	346	365	384	403
L2	49	68	87	106	125	144	163	182	201	220	239	258	277	296	315	334	353	372	391

Type 41 Manifold: Bottom Ported/SS3YJ7-41- Stations -01 □-Q

Grommet (G)

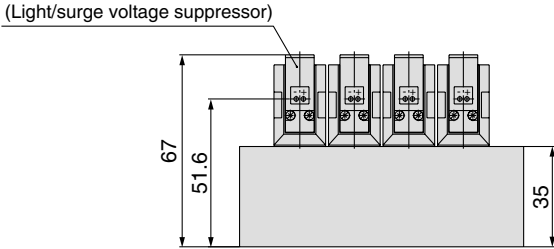
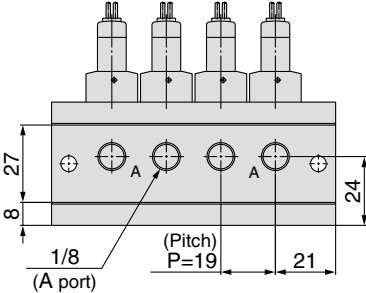

Series SYJ700

Type 21R Manifold: Top Ported (External Pilot Type)/SS3YJ7-21R- Stations (-00)-Q

Grommet (G)

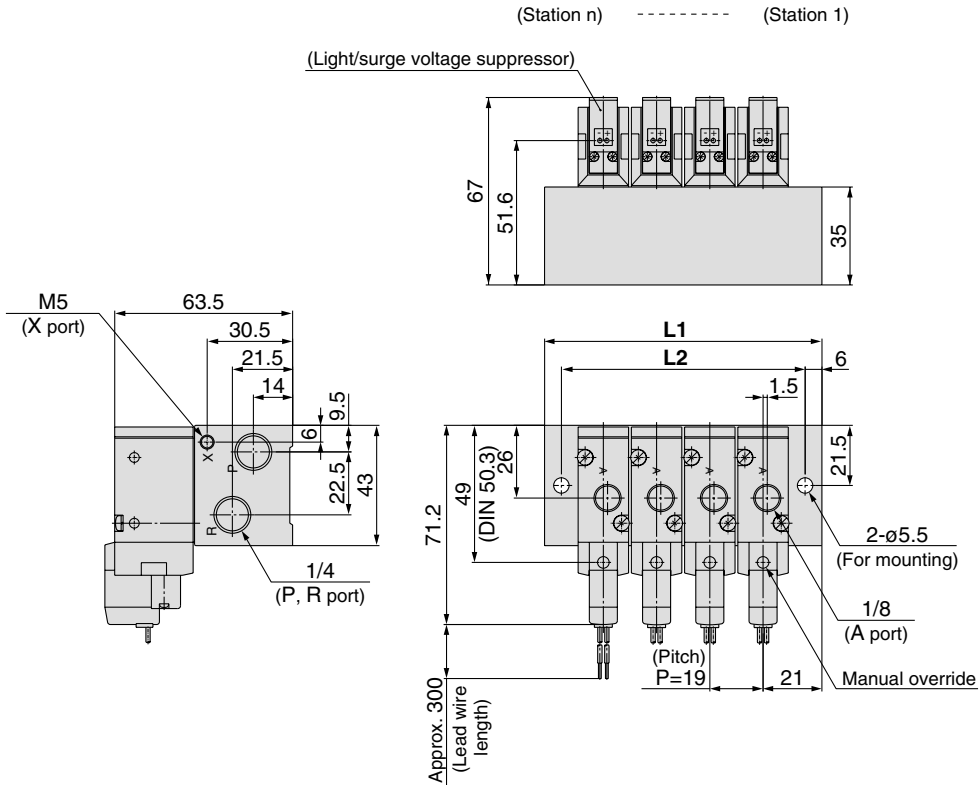

L plug connector (L)

M plug connector (M)

DIN terminal (D)

M8 connector (WO)

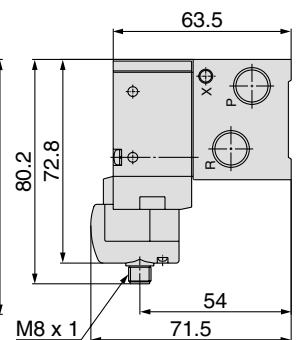
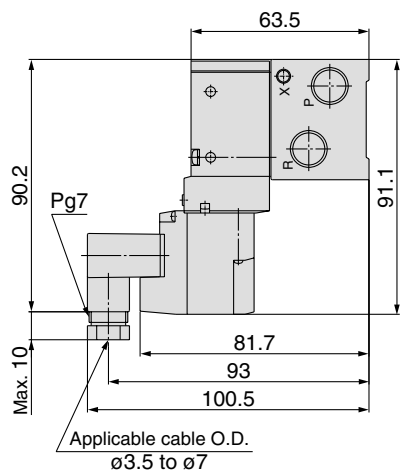
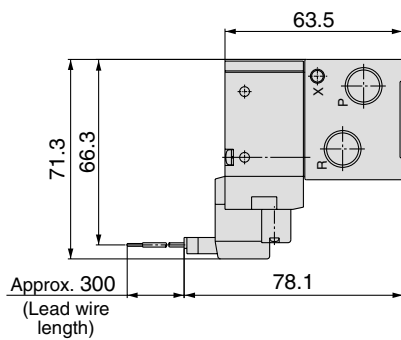
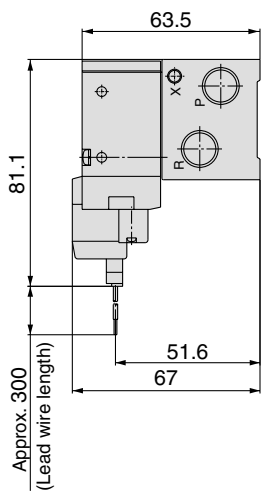

* Refer to back page 10 for dimensions with connector cable.

Station n	Station 2	3	4	5	6	7	8	9	10	11	12	13	14	15	16	17	18	19	Station 20
L1	61	80	99	118	137	156	175	194	213	232	251	270	289	308	327	346	365	384	403
L2	49	68	87	106	125	144	163	182	201	220	239	258	277	296	315	334	353	372	391

Type 42R Manifold: Side Ported/SS3YJ7-42R- Stations -01, C6 N7 C8, N9 □-Q

Grommet (G)

For 1/8

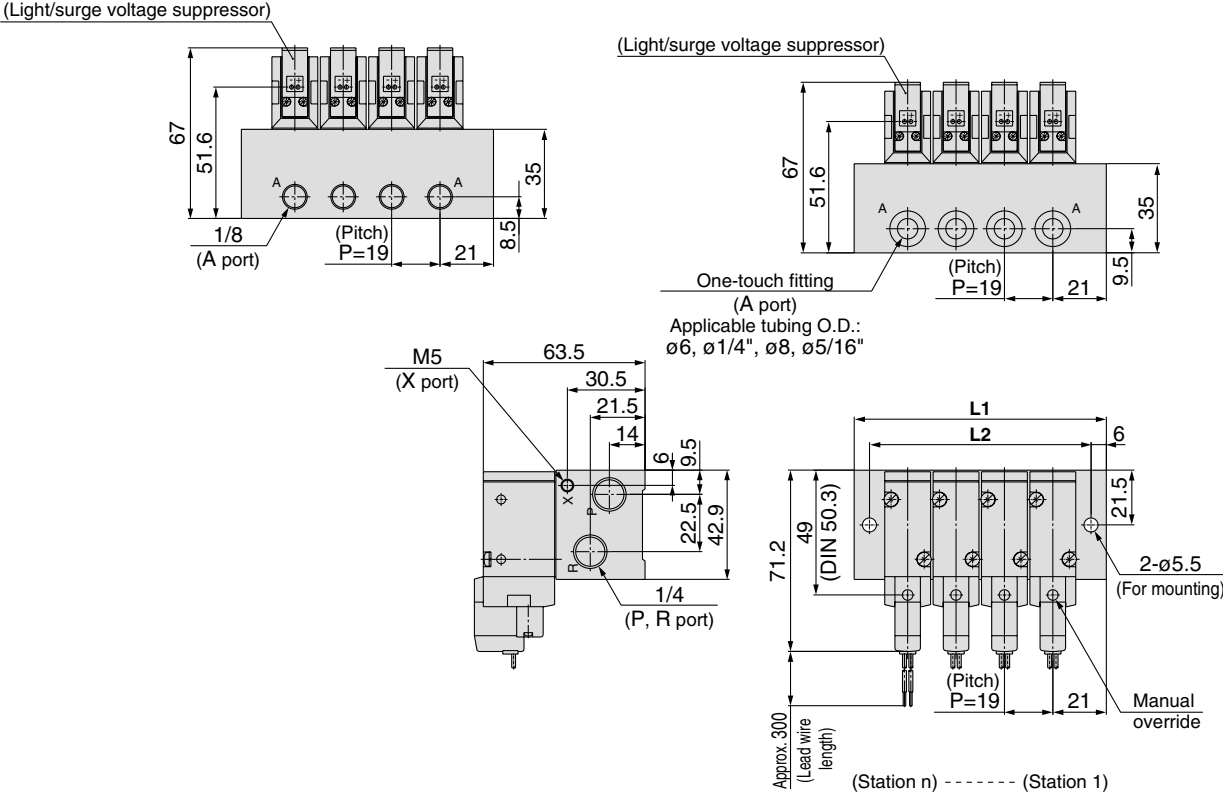

L plug connector (L)

M plug connector (M)

DIN terminal (D)

M8 connector (WO)

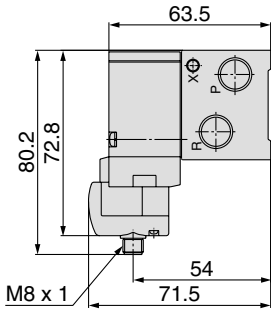
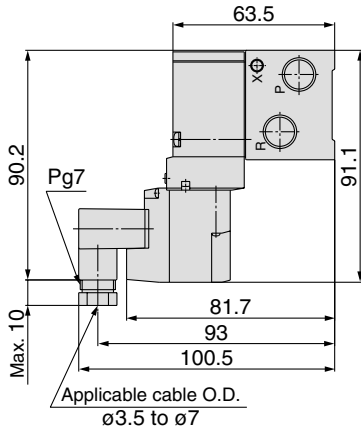
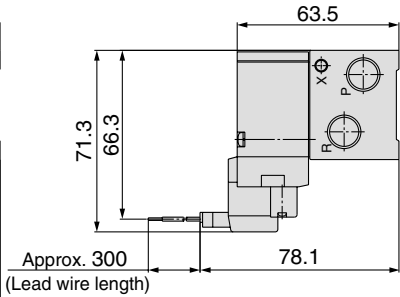
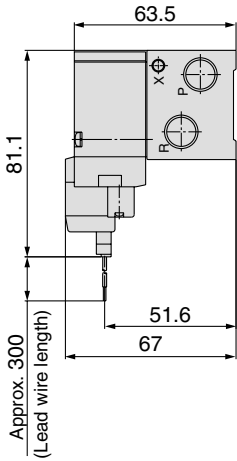

* Refer to back page 10 for dimensions with connector cable.

Station n	Station 2	3	4	5	6	7	8	9	10	11	12	13	14	15	16	17	18	19	Station 20
L1	61	80	99	118	137	156	175	194	213	232	251	270	289	308	327	346	365	384	403
L2	49	68	87	106	125	144	163	182	201	220	239	258	277	296	315	334	353	372	391

Series SYJ700

Type 41R Manifold: Bottom Ported (External Pilot Type)/SS3YJ7-41R- Stations -01□-Q

Grommet (G)

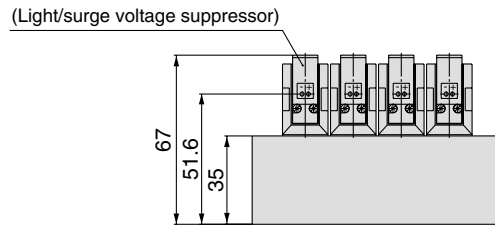
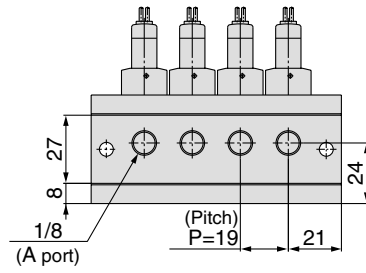

3 Port/Air Operated Valve

Series SYJA300

How to Order

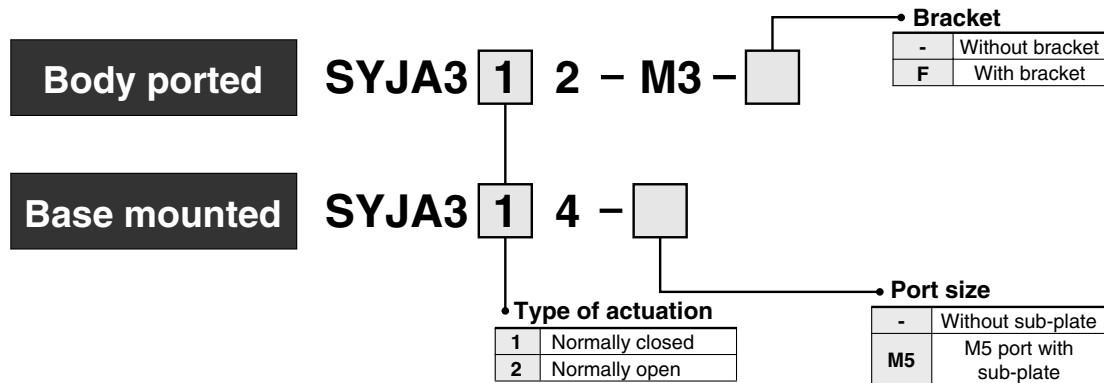

How to Order Manifold Base

Same manifolds as series SYJ300 are prepared.

SS3YJA3 -

* Instruct by specifying the valves and blanking plate assembly to be mounted on the manifold along with the manifold base model no.

(Ex.) **SS3YJA3-41-03-M3** 1 set
 * SYJA314 1 set
 * SYJA324 1 set
 * SYJ300-10-2A 1 set

↳ The asterisk denotes the symbol for assembly. Prefix it to the part nos. of the solenoid valve, etc.

Compact and lightweight

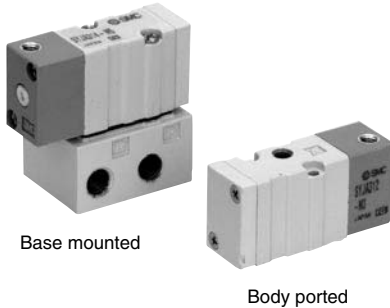

Specifications

Fluid	Air
Operating pressure range (MPa)	0.15 to 0.7
Pilot pressure range (MPa) ^{Note 1)}	Operating pressure range to 0.7
Ambient and fluid temperature (°C)	-10 to 50 (No freezing. Refer to back page 2.)
Lubrication	Not required
Mounting orientation	Unrestricted
Impact/Vibration resistance (m/s ²) ^{Note 2)}	150/30



Note 1) Be certain that pressure within operating pressure range be supplied to supply port, because return pressure is introduced from supply port {1(P)} for activation.

Note 2) Impact resistance: No malfunction resulted from the impact test using a drop impact tester. The test was performed on the axis and right angle directions of the main valve, when pilot signal is ON and OFF. (Value in the initial state)

Vibration resistance: No malfunction occurred in one sweep test between 45 and 2000 Hz. Test was performed to axis and right angle directions of the main valve when pilot signal is ON and OFF. (Value in the initial state)

With Bracket

Air operated valve type	SYJA3 ¹ / ₂ -M3-F
-------------------------	---

JIS Symbol

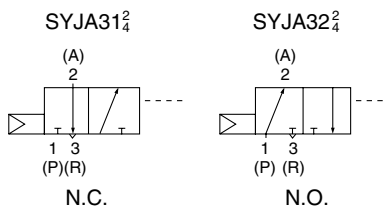

Pilot Pressure Range

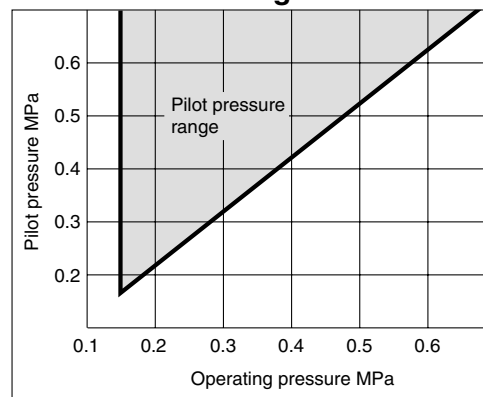

⚠ Caution

Refer to back page 1 through to 4 for Safety Instructions and Common Precautions.

Flow Characteristics/Weight

Valve model	Type of actuation	Port size	Flow characteristics								Pilot port size	Weight (g)	Effective area (mm ²)	
			1→2 (P→A)				2→3 (A→R)							
			C [dm ³ /(s bar)]	b	Cv	Q _l /min(ANR)*	C [dm ³ /(s bar)]	b	Cv	Q _l /min(ANR)*				
Body ported	SYJA312-M3	N.C.	M3	—	—	—	—	—	—	—	—	M3	18	0.9
	SYJA322-M3	N.O.		—	—	—	—	—	—	—	—			
Base mounted (with sub-plate)	SYJA314-M5	N.C.	M5	0.41	0.18	0.086	97	0.35	0.33	0.086	97	M3	39 (Without sub-plate 18)	—
	SYJA324-M5	N.O.		0.36	0.31	0.089	92	0.36	0.31	0.089	92			



Note) Model No. for base mounted style without sub-plate is SYJA3¹/₂-M3-F.

*These values have been calculated according to ISO 6358 and represent the flow rate measured in standard conditions at an upstream pressure of 0.6MPa (relative pressure) and a differential pressure of 0.1MPa.

Series SYJA300

Dimensions

Body ported: SYJA3□2-M3(-F)

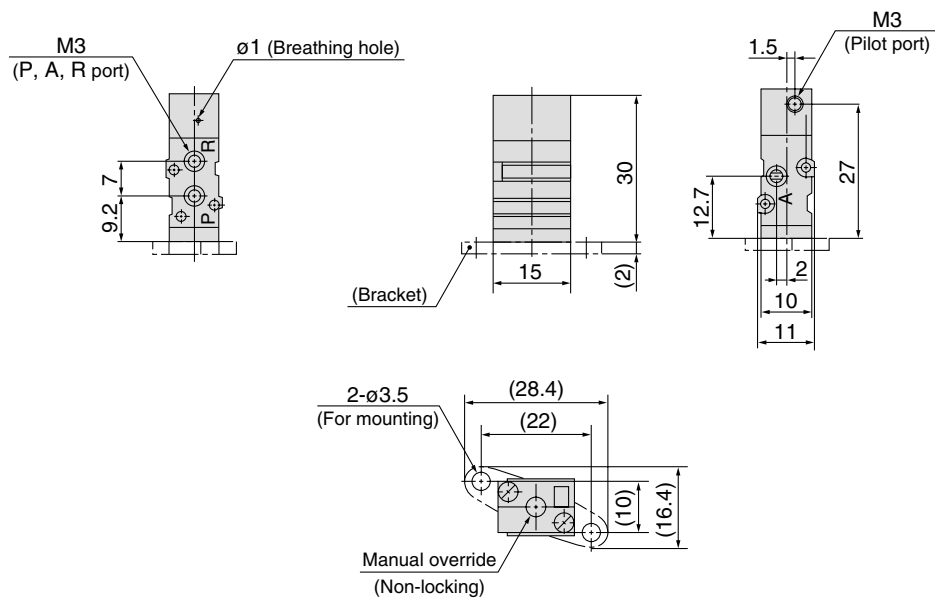

Base mounted: SYJA3□4-M5

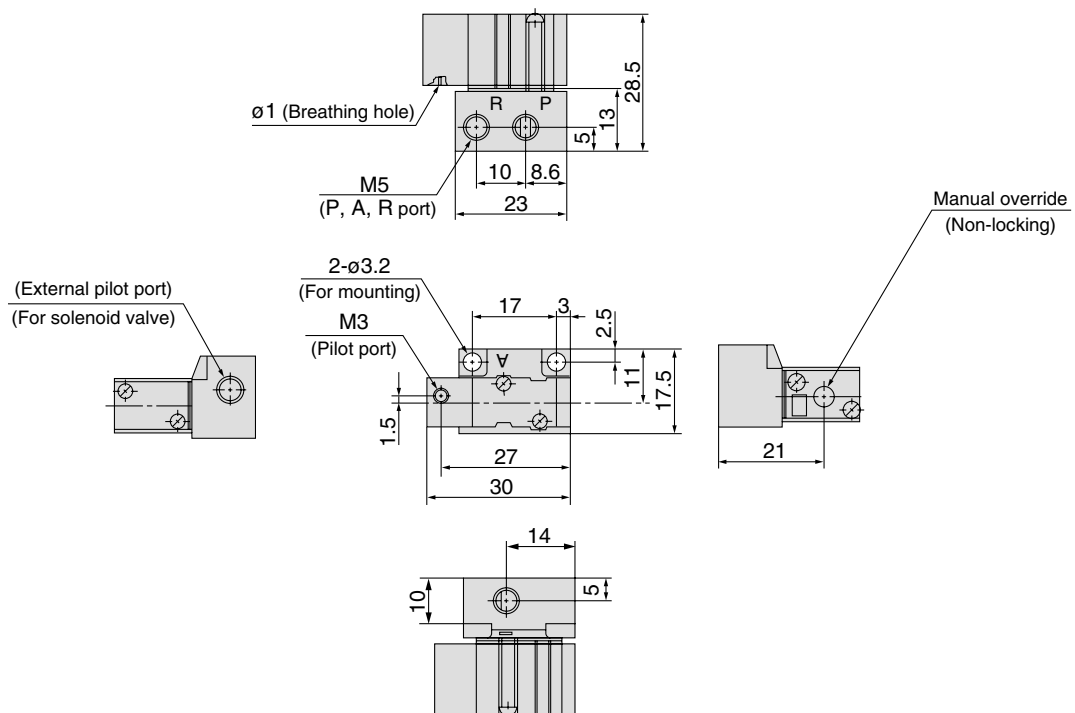

3 Port/Air Operated Valve

Series SYJA500/700

How to Order

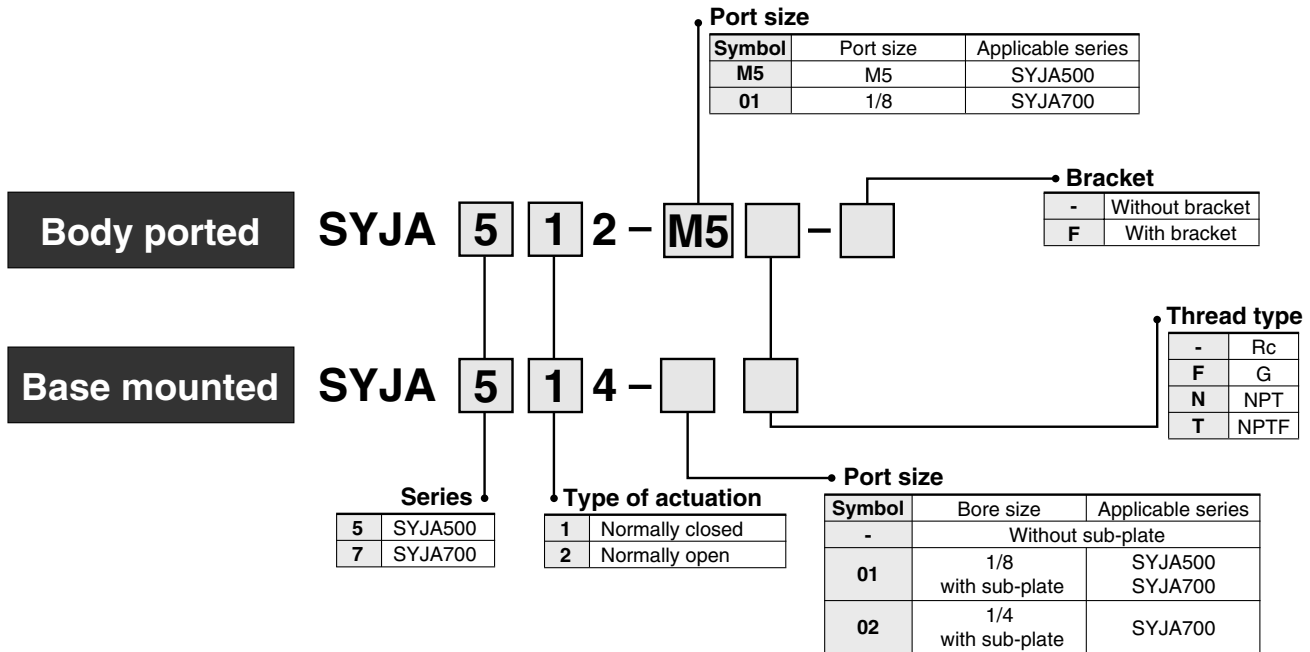

How to Order Manifold Base

Same manifolds as series SYJ500/700 are prepared.

(For SYJA500) **SS3YJA5** -

(For SYJA700) **SS3YJA7** -

* Instruct by specifying the valves and blanking plate assembly to be mounted on the manifold along with the manifold base model no.

(Ex.) **SS3YJA5-40-03-01** 1 set (Ex.) **SS3YJA7-41-03-01** 1 set
 * SYJA514 2 sets * SYJA714 2 sets
 * SYJ500-10-3A 1 set * SYJ700-10-2A 1 set

↳ The asterisk denotes the symbol for assembly. Prefix it to the part nos. of the solenoid valve, etc.

Series SYJA500/700

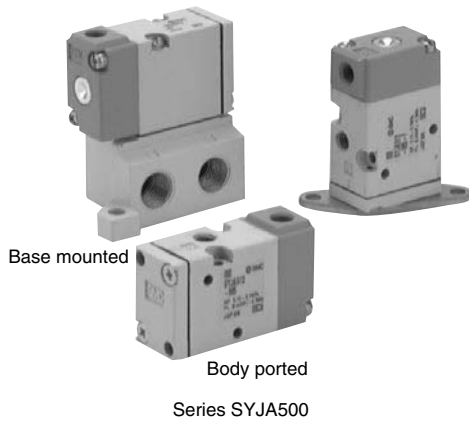

Specifications

Fluid	Air
Operating pressure range (MPa)	0.15 to 0.7
Pilot pressure range (MPa) ^{Note 1)}	(0.4 x P + 0.1) to 0.7 P: Operating pressure range
Ambient and fluid temperature (°C)	-10 to 50 (No freezing. Refer to back page 2.)
Lubrication	Not required (Use turbine oil Class 1 ISO VG32, if lubricated.)
Mounting orientation	Unrestricted
Impact/Vibration resistance (m/s ²) ^{Note 2)}	300/50

Note 1) Be certain that pressure within operating pressure range be supplied to supply port, because return pressure is introduced from supply port {1(P)} for activation.

Note 2) Impact resistance: No malfunction resulted from the impact test using a drop impact tester. The test was performed on the axis and right angle directions of the main valve, when pilot signal is ON and OFF. (Value in the initial state)

Vibration resistance: No malfunction occurred in one sweep test between 45 and 2000 Hz. Test was performed to axis and right angle directions of the main valve when pilot signal is ON and OFF. (Value in the initial state)



With Bracket

Air operated valve type	SYJA5 ¹ / ₂ -2-M5-F, SYJA7 ¹ / ₂ -2-01-F
-------------------------	--

Note) Bracket is not mounted.

JIS Symbol

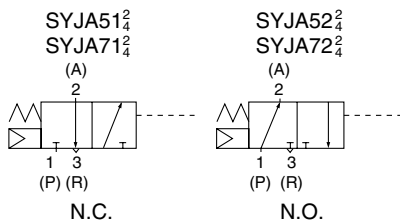

Pilot Pressure Range

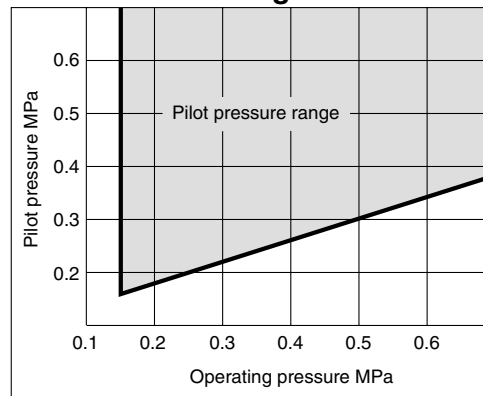

Caution

Refer to back page 1 through to 4 for Safety Instructions and Common Precautions.

Flow Characteristics/Weight

Valve model	Type of actuation	Port size	Flow characteristics								Pilot port size	Weight (g)	
			1→2 (P→A)				2→3 (A→R)						
			C [dm ³ /(s bar)]	b	Cv	Q _l [min(ANR)]*	C [dm ³ /(s bar)]	b	Cv	Q _l [min(ANR)]*			
Body ported	SYJA512-M5	N.C.	M5	0.53	0.45	0.14	150	0.47	0.39	0.12	127	M5	45
	SYJA522-M5	N.O.		0.66	0.45	0.18	186	0.66	0.45	0.18	186		
Base mounted (with sub-plate)	SYJA514-01	N.C.	Rc 1/8	1.2	0.41	0.32	329	1.1	0.46	0.32	313	M5	75 (Without sub-plate 45)
	SYJA524-01	N.O.		1.3	0.37	0.33	346	1.2	0.48	0.34	347		
Body ported	SYJA712-01	N.C.	Rc 1/8	2.8	0.43	0.77	779	2.5	0.51	0.76	741	M5	80
	SYJA722-01	N.O.		2.7	0.38	0.72	724	2.4	0.42	0.69	662		
Base mounted (with sub-plate)	SYJA714-01	N.C.	Rc 1/8	2.9	0.32	0.71	747	2.7	0.34	0.69	705	M5	130 (Without sub-plate 80)
	SYJA714-02		Rc 1/4	3.0	0.31	0.74	768	2.6	0.33	0.66	674		
	SYJA724-01	N.O.	Rc 1/8	2.8	0.21	0.70	674	2.3	0.45	0.63	649		
	SYJA724-02		Rc 1/4	2.7	0.31	0.68	691	2.3	0.48	0.64	665		

Note) Model No. for base mounted style without sub-plate is SYJA5¹/₂4, SYJA7¹/₂4.

*These values have been calculated according to ISO 6358 and represent the flow rate measured in standard conditions at an upstream pressure of 0.6MPa (relative pressure) and a differential pressure of 0.1MPa.

Dimensions

Series SYJA500

Body ported: SYJA5□2-M5(-F)

Base mounted: SYJA5□4-01□

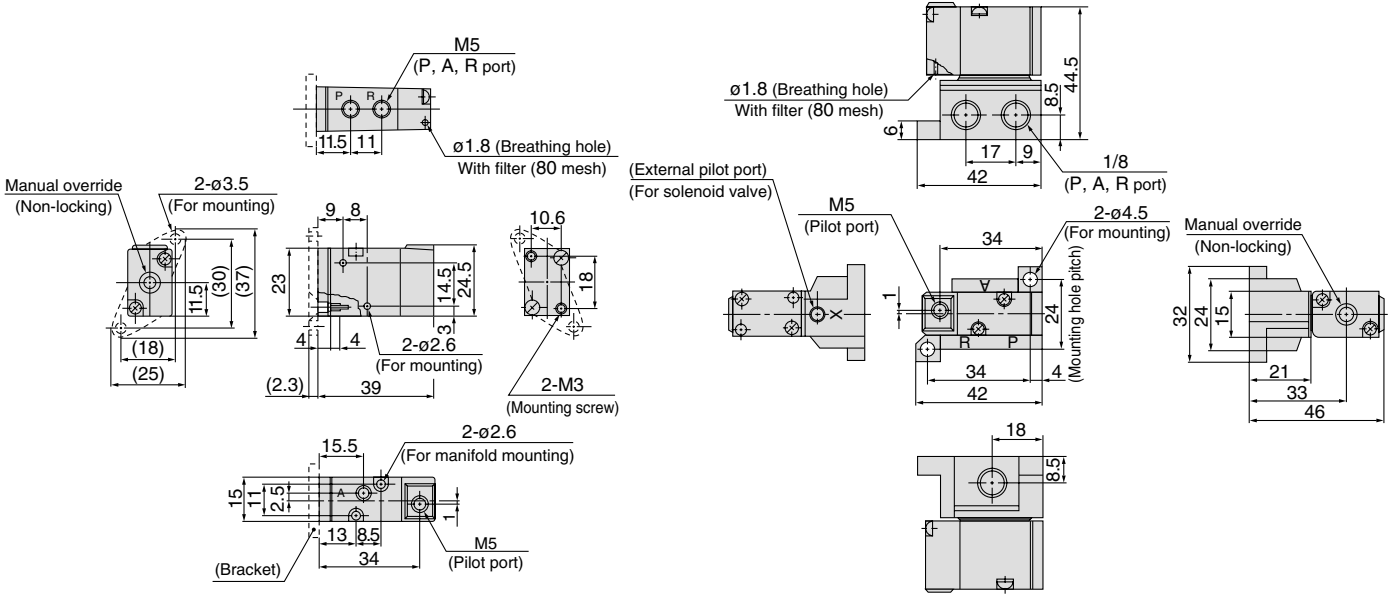

Series SYJA700

Body ported: SYJA7□2-01□ (-F)

Base mounted: SYJA7□4-01□

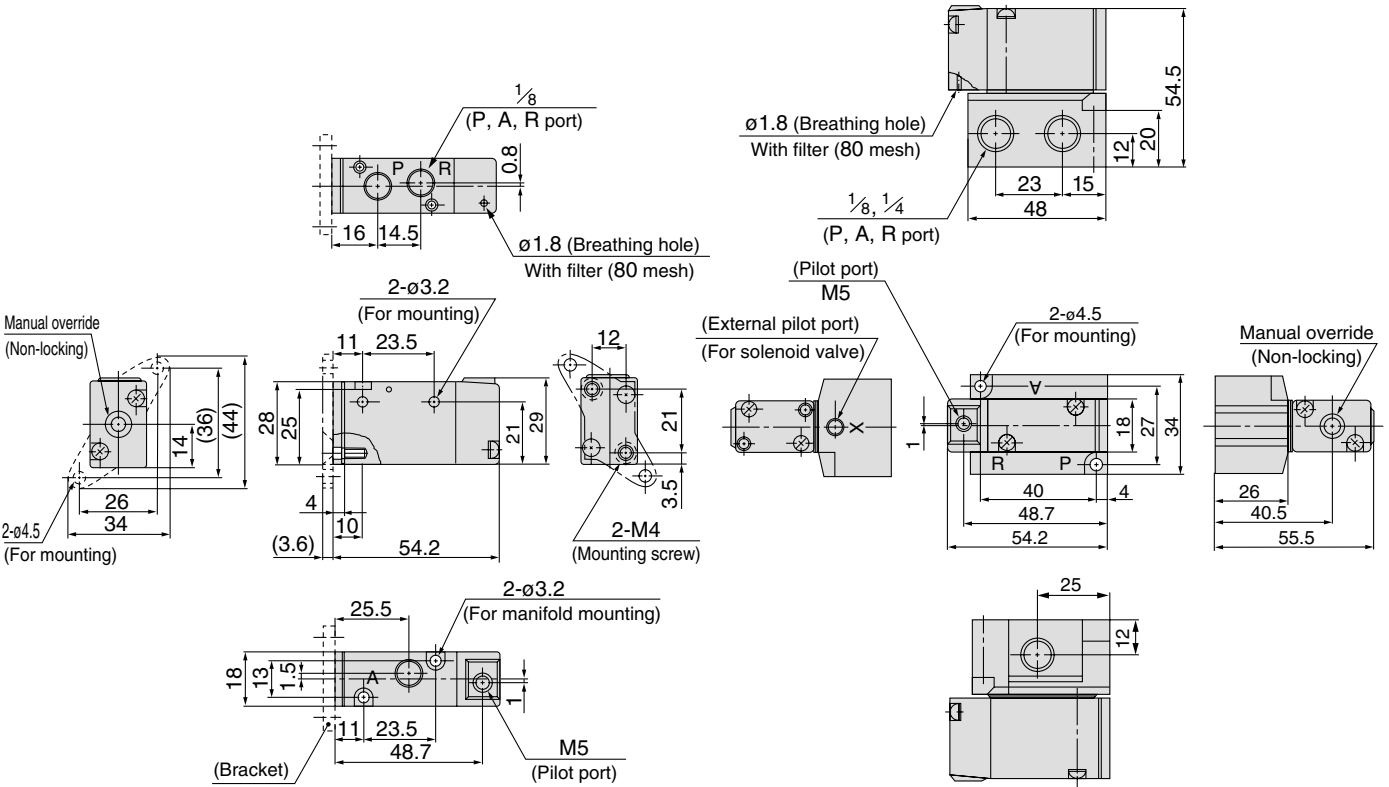

Made to Order

DIN Connector Conforming to EN-175301-803C (former DIN 43650C)

DIN connector type that conforms to the 8 mm pitch standards between DIN terminals.

How to Order Valve

Rated voltage

DC		AC (50/60 Hz)	
5	24 VDC	1	100 VAC
6	12 VDC	2	200 VAC
V	6 VDC	3	110 VAC [115 VAC]
S	5 VDC	4	220 VAC [230 VAC]
R	3 VDC		

Light/surge voltage suppressor

-	Without light/surge voltage suppressor
S	With surge voltage suppressor
Z	With light/surge voltage suppressor

* YOZ is not available.
* For AC voltage valves there is no "S" option. It is already built-in to the rectifier circuit.

Bracket

-	Without bracket
F	With bracket

* Bracket is not mounted.
* External pilot type does not exist.

Series

5	SYJ500
7	SYJ700

Type of actuation

1	Normally closed
2	Normally open

Port size

M5	M5
01	1/8 (SYJ700 only)

Body ported SYJ 5 1 2 [] 5 Y [] [] M5 [] Q

Base mounted SYJ 5 1 4 [] 5 Y [] [] 01 [] Q

Body option

-	Pilot valve individual exhaust
M	Common exhaust type for main and pilot valve
R	External pilot*

* SYJ5□R is only for manifold use.

Electrical entry

Y: With connector

YO: Without connector

Port size

-	Without sub-plate
01	1/8 port With sub-plate
02	1/4 port With sub-plate (SYJ700 only)

Thread type

-	Rc
F	G
N	NPT
T	NPTF

Manual override

-	Non-locking push type
D	Push-turn locking slotted type
E	Push-turn locking lever type

How to Order Pilot Valve Assembly

V115-5 Y []

Rated voltage

Specifications	
5	24 VDC
6	12 VDC

AC (50/60 Hz)

1	100 VAC
2	200 VAC
3	110 VAC [115 VAC]
4	220 VAC [230 VAC]

Light/surge voltage suppressor

-	Without light/surge voltage suppressor
S	With surge voltage suppressor
Z	With light/surge voltage suppressor

* YOZ is not available.
* For AC voltage valves there is no "S" option. It is already built-in to the rectifier circuit.

Electrical entry

Y	DIN	With connector
YO	terminal	Without connector

DIN Connector Part No.

Without light	SY100-82-1	
With light		
Rated voltage	Voltage symbol	Model no.
24 VDC	24 VN	SY100-82-3-05
12 VDC	12 VN	SY100-82-3-06
100 VDC	100 VN	SY100-82-3-01
200 VDC	200 VN	SY100-82-3-02
110 VAC (115 VAC)	110 VN	SY100-82-3-03
220 VAC (230 VAC)	220 VN	SY100-82-3-04

Caution

- Use caution in wiring because it won't meet the IP65 (enclosure) standard if you use the other cord than prescribed heavy-duty cord of size (ø3.5 to ø7.5). Also be sure to tighten the ground nut and holding screw with the prescribed torque range. For how to use DIN terminal (wiring procedures, procedures for changing electrical entries, precautions, applicable cable, circuit diagram), refer to page 66.
- D type DIN connector with 9.4 mm pitch between terminals is not interchangeable.
- DIN connector except D type has the "N" indication in the end of voltage symbol. In case of DIN connector without light, "N" is not indicated. Please refer to the name plate to distinguish.
- Dimensions are completely the same as D type connector.
- When exchanging the pilot valve assembly only, "V115-□D" is interchangeable with "V115-□Y". Do not replace V111 (G, H, L, M, W) to V115-□D/□Y (DIN terminal), and vice versa.

Series SYJ300/500/700

Made to Order



M8 Connector Conforming to IEC60947-5-2

M8 Connector type conforming to IEC60947-5-2 standard.

How to Order Valve

Rated voltage

DC	
5	24 VDC
6	12 VDC
V	6 VDC
S	5 VDC
R	3 VDC

Series

3	SYJ300
5	SYJ500
7	SYJ700

Type of actuation

1	Normally closed
2	Normally open

Light/surge voltage suppressor

-	Without light/surge voltage suppressor
S	With surge voltage suppressor
Z	With light/surge voltage suppressor
R	With surge voltage suppressor (Non-polar type)
U	With light/surge voltage suppressor (Non-polar type)

Bracket

-	Without bracket
F	With bracket

Port size

M3	M3 (SYJ300 only)
M5	M5
01	1/8 (SYJ700 only)

Body option

-	Pilot valve individual exhaust
M	Common exhaust type for main and pilot valve
R	External pilot

* SYJ3□2R, SYJ5□2R, SYJ7□2R, are only for manifold use.

Electrical entry

WAO: Without connector cable

WA1: With connector cable (Length 0,3 m)
 WA2: With connector cable (Length 0,5 m)
 WA3: With connector cable (Length 1 m)
 WA4: With connector cable (Length 2 m)
 WA7: With connector cable (Length 5 m)

Thread type

-	Rc
F	G
N	NPT
T	NPTF

Port size

-	Without sub-plate
M5	M5 port With sub-plate (SYJ300 only)
01	1/8 port With sub-plate
02	1/4 port With sub-plate (SYJ700 only)

Manual override

-	Non-locking push type
D	Push-turn locking slotted type
E	Push-turn locking lever type

3 port
(For manifold type 20, 20R, 21R)

3 port
(For sub-plate style, manifold type 40, 40R, 41, 41R, S41, 42, S42, 42R, S42R)

Body ported SYJ 5 1 2 □ 5 WAO □ □ M5 □ Q

Base mounted SYJ 5 1 4 □ 5 WAO □ □ 01 □ Q

How to Order Pilot Valve Assembly

V115 — 5 WAO □

Rated voltage

DC	
5	24 V DC
6	12 V DC
V	6 V AC
S	5 V DC
R	3 V DC

Light/surge voltage suppressor

-	Without light/surge voltage suppressor
S	With surge voltage suppressor
Z	With light/surge voltage suppressor
R	With surge voltage suppressor (Non polar- type)
U	With light/surge voltage suppressor (Non polar- type)

Electrical entry

WAO	Without connector cable
WA□	With connector cable

Note: □ is for cable length. Please refer to Specific Product Precautions 6.

Series SYJ500/700

Made to Order



(For detailed specifications, delivery and pricing, please contact SMC.)

Body Ported External Pilot

How to Order Applicable solenoid valve series/SYJ5□2R, SYJ7□2R

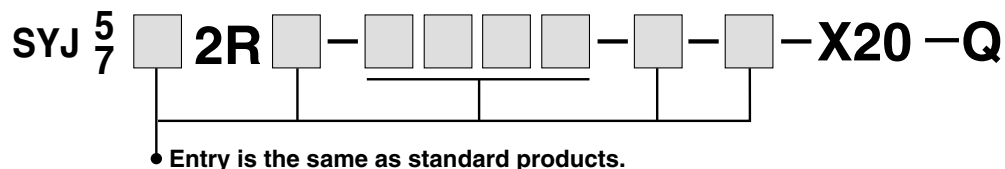

Operating Pressure Range MPa

Operating pressure range	-100 kPa to 0.7
Pilot pressure range	0.15 to 0.7

Dimensions

SYJ500: 8 mm longer in total length

SYJ700: 8 mm longer in total length

External Pilot Port

Series	Port size
SYJ500, SYJ700	M5

JIS Symbol

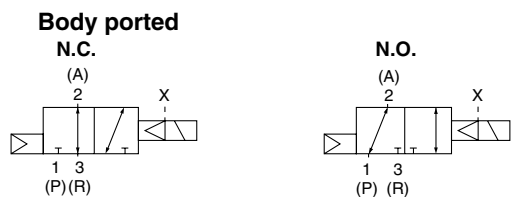



Series SYJ Safety Instructions

These safety instructions are intended to prevent a hazardous situation and/or equipment damage. These instructions indicate the level of potential hazard by labels of "Caution", "Warning" or "Danger". To ensure safety, be sure to observe ISO 4414 ^{Note 1)}, JIS B 8370 ^{Note 2)} and other safety practices.

⚠ Caution : Operator error could result in injury or equipment damage.

⚠ Warning : Operator error could result in serious injury or loss of life.

⚠ Danger : In extreme conditions, there is a possible result of serious injury or loss of life.

Note 1) ISO 4414: Pneumatic fluid power--General rules relating to systems.

Note 2) JIS B 8370: General Rules for Pneumatic Equipment

⚠ Warning

1. The compatibility of pneumatic equipment is the responsibility of the person who designs the pneumatic system or decides its specifications.

Since the products specified here are used in various operating conditions, their compatibility for the specific pneumatic system must be based on specifications or after analysis and/or tests to meet your specific requirements. The expected performance and safety assurance will be the responsibility of the person who has determined the compatibility of the system. This person should continuously review the suitability of all items specified, referring to the latest catalogue information with a view to giving due consideration to any possibility of equipment failure when configuring a system.

2. Only trained personnel should operate pneumatically operated machinery and equipment.

Compressed air can be dangerous if an operator is unfamiliar with it. Assembly, handling or repair of pneumatic systems should be performed by trained and experienced operators.

3. Do not service machinery/equipment or attempt to remove components until safety is confirmed.

1. Inspection and maintenance of machinery/equipment should only be performed once measures to prevent falling or runaway of the driver objects have been confirmed.
2. When equipment is to be removed, confirm the safety process as mentioned above. Cut the supply pressure for this equipment and exhaust all residual compressed air in the system.
3. Before machinery/equipment is restarted, take measures to prevent shooting-out of cylinder piston rod, etc.

4. Contact SMC if the product is to be used in any of the following conditions:

1. Conditions and environments beyond the given specifications, or if product is used outdoors.
2. Installation on equipment in conjunction with atomic energy, railway, air navigation, vehicles, medical equipment, food and beverages, recreation equipment, emergency stop circuits, clutch and brake circuits in press applications, or safety equipment.
3. An application which has the possibility of having negative effects on people, property, or animals, requiring special safety analysis.



3 Port Solenoid Valves/Common Precautions 1

Be sure to read before handling.

Design

Warning

1. Actuator drive

When an actuator, such as a cylinder, is to be driven using a valve, take appropriate measures to prevent potential danger caused by actuator operation.

2. Effect of back pressure when using a manifold

Use caution when valves are used on a manifold, as actuator malfunction due to back-pressure may occur.

Note: Extra care should be taken when driving a single acting cylinder. Take measures to prevent potential malfunction.

3. Holding of pressure (including vacuum)

Since valves are subject to air leakage, they cannot be used for applications such as holding pressure (including vacuum) in a pressure vessel.

4. Cannot be used as an emergency shut off valve, etc.

The valves presented in this catalogue are not designed for safety applications such as an emergency shut off valve. If the valves are used in this type of system, other reliable safety assurance measures should also be adopted.

5. Maintenance space

The installation should allow sufficient space for maintenance activities (removal of valve, etc.).

6. Release of residual pressure

Provide a residual pressure release function for maintenance purpose.

7. Vacuum applications

When a valve is used for vacuum switching, etc., take measures against the suction of external dust or other contaminants from vacuum pads and exhaust ports, etc. Moreover, an external pilot type valve should be used in this case. Contact SMC in case of an internal pilot type or air operated valve, etc.

8. Ventilation

When a valve is used inside a sealed control panel, etc., provide ventilation to prevent a pressure increase caused by exhausted air inside the control panel or temperature rise caused by the heat generated by the valve.

Selection

Warning

1. Confirm the specification.

The products presented in this catalogue are designed only for use in compressed air systems (including vacuum). Do not operate at pressures or temperatures, etc., beyond the range of specifications, as this can cause damage or malfunction. (Refer to specifications.)

Contact SMC when using a fluid other than compressed air (including vacuum).

2. Extended periods of continuous energisation

• Continuous energisation of the valve for extended periods of time may have an adverse effect on the solenoid valve performance and the peripheral equipment due to temperature rises caused by the heat generation of the coil. Consult with SMC if valves will be continuously energised for extended periods of time or the energised period per day will be longer than the de-energised period. It is also possible to shorten the energisation period by using valves of the N.O. (normally open) type.

• When solenoid valves are mounted in a control panel, employ measures to radiate excess heat, so that temperatures remain within the valve specification range. Use special caution when three or more stations sequentially aligned on the manifold are continuously energised since this will cause a drastic temperature rise. (As for AC specifications, since the applicable products are ready to provide separately, contact SMC.)

Selection

Caution

1. Leakage voltage

When using a resistor in parallel with the switching element or using a C-R element (surge voltage suppressor) for protection of the switching element, note that leakage voltage will increase due to leakage current flowing through the resistor or C-R element. Limit the amount of residual leakage voltage to the following value:

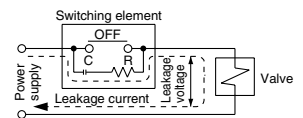

With DC coil : 3% or less of rated voltage

With AC coil : 8% or less of rated voltage

2. Solenoid valve drive for AC with solid state output (SSR, TRIAC output, etc.)

1) Current leakage

When using a snubber circuit (C-R element) for surge protection of the output element, a very small electric current will still continue to flow in spite of the OFF state. This results in the valve not returning. In the cases when exceeding the tolerance as shown above, take measures to install a bleeder resistor.

2) Minimum load allowable amount (Min. load current)

When the consumption current of a valve is less than the output element's minimum load allowable volume or the margin is small, the output element may not be switched normally. Please confirm SMC.

3. Surge voltage suppressor

If a surge protection circuit contains non-ordinary diodes such as Varistor, a residual voltage that is in proportion to the protective elements and the rated voltage will remain. Therefore, give consideration to surge voltage protection of the controller. In the case of diodes, the residual voltage is approximately 1 V.

4. Use in low temperature environments

Unless otherwise indicated in the specifications for each valve, operation is possible to -10°C , but appropriate measures should be taken to avoid solidification or freezing of drainage and moisture, etc.



3 Port Solenoid Valves/Common Precautions 2

Be sure to read before handling.

Selection

⚠ Caution

5. Operation for air blowing

When using a solenoid valve for air blow, use an external pilot type.

Take note that when internal pilots and external pilots are used on the same manifold, the pressure drop caused by the air blowing can have an effect on the internal pilot type valves. Moreover, when compressed air within the pressure range of the established specifications is supplied to the external pilot port, and a double solenoid valve is used for air blowing, the solenoids should normally be energised when air is being blown.

6. Mounting orientation

Rubber seal: Refer to the specifications of each series.

Mounting

⚠ Warning

1. If air leakage increases or equipment does not operate properly, stop operation.

Check mounting conditions when air and power supplies are connected. Initial function and leakage tests should be performed after installation.

2. Instruction manual

Mount and operate the product after reading the manual carefully and understanding its contents.

Also keep the manual where it can be referred to as necessary.

3. Painting and coating

Warnings or specifications printed or pasted on the product should not be erased, removed or covered up. Consult with SMC if paint is to be applied to resinous parts, as this may have an adverse effect due to the paint solvent.

Piping

⚠ Caution

1. Preparation before piping

Before piping is connected, it should be thoroughly blown out with air (flushing) or washed to remove chips, cutting oil and other debris from inside the pipe.

2. Wrapping of sealant tape

When connecting pipes and fittings, etc., be sure that chips from the pipe thread and sealing materials do not get inside the valve. Furthermore, when pipe tape is used, leave 1.5 to 2 thread ridges exposed at the end of the threads.

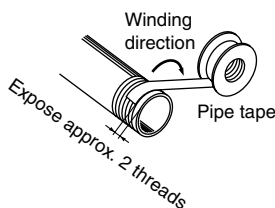

Piping

3. Screwing in fittings

When connecting fittings to valves, tighten as indicated below.

1) For M5 type

(1) When using SMC fittings, follow the guidelines below.

M5: After tightening by hand, tighten an additional 1/6 turn with a tightening tool. However, if miniature fittings are used, tighten an additional 1/4 turn with a tightening tool after tightening by hand. For fittings with gaskets in 2 locations, e.g., universal elbow or universal tee, tighten an additional 1/2 turn.

Note) If fittings are over-tightened, air leakage may result due to breaking of fitting threads or deformation of the gaskets. However, if fittings are not tightened sufficiently, loosening of the threads and air leakage and may occur.

(2) When fittings other than SMC fittings are used, follow the instructions of the respective fitting manufacturer.

2) For threads

Tightening Torque for Piping

Connection threads	Proper tightening torque N·m
1/8	7 to 9
1/4	12 to 14

4. Connection of piping to products

When connecting piping to a product, refer to its instruction manual to avoid mistakes regarding the supply port, etc.

Wiring

⚠ Caution

1. Polarity

When connecting power to a DC specification solenoid valve equipped with (indicator light) surge voltage suppressor, confirm whether or not there is polarity.

If there is polarity, take note of the following points.

Without built-in diode to protect polarity (including power saving circuit):

If a mistake is made regarding polarity, the diode in the valve, the control device switching element or power supply equipment, etc., may burn out.

With diode to protect polarity:

If a mistake is made regarding polarity, it will not be possible to switch the valve.

2. Applied voltage

When electric power is connected to a solenoid valve, be careful to apply the proper voltage. Improper voltage may cause malfunction or coil damage.

3. Confirm the connections.

After completing the wiring, confirm that the connections are correct.



3 Port Solenoid Valves/Common Precautions 3

Be sure to read before handling.

Lubrication

⚠ Caution

1. Lubrication

- 1) The valve has been lubricated for life at the factory, and does not require any further lubrication.
- 2) In the event that it is lubricated, use class 1 turbine oil (without additives), ISO VG32.
However, once lubrication is applied it must be continued, as loss of the original lubricant may lead to malfunction. Contact SMC regarding class 2 turbine oil (with additives), ISO VG32.

Air Supply

⚠ Warning

1. Use clean air.

Do not use compressed air which contains chemicals, synthetic oils containing organic solvents, salts or corrosive gases, etc., as this can cause damage or malfunction.

⚠ Caution

1. Install air filters.

Install air filters close to valves at their upstream side. A filtration degree of 5 µm or less should be selected.

2. Install an air dryer, after cooler or Drain Catch (water separator), etc.

Air that includes excessive drainage may cause malfunction of valves and other pneumatic equipment. To prevent this, install an air dryer, after-cooler or water separator, etc.

3. If excessive carbon dust is generated, eliminate it by installing mist separators at the upstream side of valves.

If excessive carbon dust is generated by the compressor, it may adhere to the inside of valves and cause malfunction.

Refer to "SMC Best Pneumatics" catalogue for compressed air quality.

Operating Environment

⚠ Warning

1. Do not use valves in atmospheres of corrosive gases, chemicals, salt water, water or steam or where there is direct contact with any of these.

2. Products with IP65 enclosures (based on IEC60529) are protected against dust and water, however, these products cannot be used in water.

Take measures to prevent water and dust from coming from the exhaust port.

3. Products compliant to IP65 satisfy the specifications by mounting each product properly. Be sure to read the Specific Product Precautions for each product.

4. Do not use in an explosive atmosphere.

Operating Environment

5. Do not use in locations subject to vibration or impact. Confirm the specifications in the main section of the catalogue.

6. A protective cover, etc., should be used to shield valves from direct sunlight.

7. Shield valves from radiated heat generated by nearby heat sources.

8. Employ suitable protective measures in locations where there is contact with water droplets, oil or welding spatter, etc.

9. When solenoid valves are mounted in a control panel or are energised for extended periods of time, employ measures to radiate excess heat, so that temperatures remain within the valve specification range.

Maintenance

⚠ Warning

1. Perform maintenance procedures as shown in the instruction manual.

If handled improperly, malfunction or damage of machinery or equipment may occur.

2. Equipment removal and supply/exhaust of compressed air

When equipment is removed, first confirm that measures are in place to prevent dropping of work pieces and run-away of equipment, etc. Then cut the supply pressure and power, and exhaust all compressed air from the system using its residual pressure release function. When the equipment is to be started again after remounting or replacement, first confirm that measures are in place to prevent lurching of actuators, etc., and then confirm that the equipment is operating normally.

3. Low frequency operation

Valves should be switched at least once every 30 days to prevent malfunction. (Use caution regarding the air supply.)

4. Manual override operation

When the manual override is operated, connected equipment will be actuated. Confirm safety before operating.

⚠ Caution

1. Drain flushing

Remove drainage from air filters regularly.



Series SYJ300/500/700 Specific Product Precautions 1

Be sure to read before handling.

Refer to back page 1 through to 4 for Safety Instructions and Common Precautions.

Manual Override Operation

Warning

When the manual override is operated, connected equipment will be actuated. Confirm safety before operating.

■ Non-locking push type [Standard]

Press in the direction of the arrow

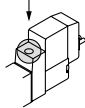

■ Push-turn slotted locking type [Type D]

While pressing, turn in the direction of the arrow.

If it is not turned, it can be operated the same way as the non-locking type.

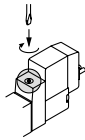

Locked position



Caution

When operating the locking type D with a screw driver, turn it gently using a watchmakers screw driver.

[Torque: Less than 0.1 N·m]

■ Push-turn locking lever type [Type E]

While pressing, turn in the direction of the arrow.

If it is not turned, it can be operated the same way as the non-locking type.

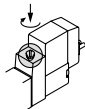

Locked position



Caution

When locking the manual override on the push-turn locking types (D, E), be sure to push it down before turning.

Turning without first pushing it down can cause damage to the manual override and trouble such as air leakage, etc.

Solenoid Valve for 200 V, 220 VAC Specifications

Warning

Solenoid valves with DIN terminal connector AC specifications have a built-in rectifier circuit in the pilot section to operate the DC coil.

With 200 V, 220 VAC specification pilot valves, this built-in rectifier generates heat when energised. The surface may become hot depending on the energised condition; therefore, do not touch the solenoid valves.

Common Exhaust Type for Main and Pilot Valve

Caution

Pilot air is exhausted through the main valve body rather than directly to atmosphere.

- Suitable for applications where exhausting the pilot valve to atmosphere would be detrimental to the surrounding working environment.
- For use in extremely dirty environments where there is the possibility that dust could enter the pilot exhaust and damage the valve.

Ensure that the piping of exhaust air is not too restrictive.

Bracket

Caution

For bracket attached styles of SYJ300, do not use it without bracket.



Series SYJ300/500/700

Specific Product Precautions 2

Be sure to read before handling.

Refer to back page 1 through to 4 for Safety Instructions and Common Precautions.

How to Use Plug Connector

⚠ Caution

1. Attaching and detaching connectors

- To attach a connector, hold the lever and connector unit between your fingers and insert straight onto the pins of the solenoid valve so that the lever's pawl is pushed into the groove and locks.
- To detach a connector, remove the pawl from the groove by pushing the lever downward with your thumb, and pull the connector straight out.

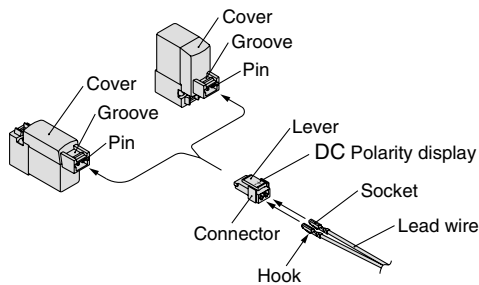

2. Crimping of lead wires and sockets

Strip 3.2 to 3.7 mm at the end of the lead wires, insert the ends of the core wires evenly into the sockets, and then crimp with a crimping tool. When this is done, take care that the coverings of the lead wires do not enter the core wire crimping area.

Use an exclusive crimping tool for crimping.
(Contact SMC for special crimping tools.)

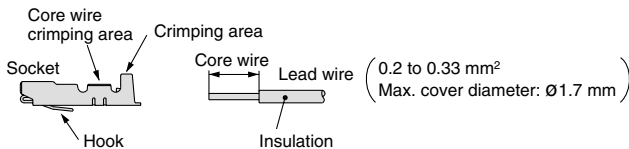

3. Attaching and detaching sockets with lead wires

• Attaching

Insert the sockets into the square holes of the connector (+, - indication), and continue to push the sockets all the way in until they lock by hooking into the seats in the connector. (When they are pushed in, their hooks open and they are locked automatically.) Then confirm that they are locked by pulling lightly on the lead wires.

• Detaching

To detach a socket from a connector, pull out the lead wire while pressing the socket's hook with a stick having a thin tip (approx. 1 mm). If the socket will be used again, first spread the hook outward.

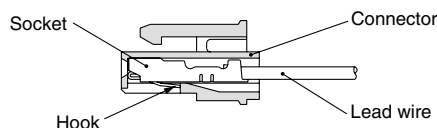

Plug Connector Lead Wire Length

⚠ Caution

Standard length is 300 mm, but the following lengths are also available.

How to Order Connector Assembly

For DC: **SY100-30-4A**

Without lead wire: **SY100-30-A**
(with connector and 2 of sockets only)

• Lead wire length

-	300 mm
6	600 mm
10	1000 mm
15	1500 mm
20	2000 mm
25	2500 mm
30	3000 mm
50	5000 mm

How to Order

Include the connector assembly part number together with the part number for the plug connector's solenoid valve without connector.

EX.) In case of 2000 mm of lead wire

For DC
SYJ312-5LO-M3
SY100-30-4A-20



Series SYJ300/500/700

Specific Product Precautions 3

Be sure to read before handling.

Refer to back page 1 through to 4 for Safety Instructions and Common Precautions.

Surge Voltage Suppressor

Caution

<For DC>
Grommet, L/M Plug Connector

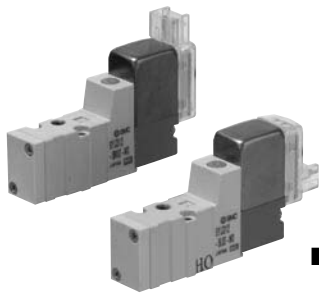

Standard type (with polarity) Surge voltage suppressor (□S)

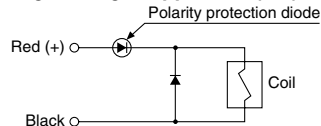

With light/surge voltage suppressor (□Z)

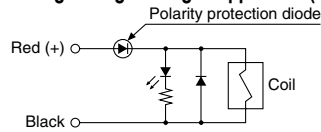

Non-polar type

With surge voltage suppressor (□R)

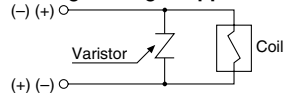

With light/surge voltage suppressor (□U)

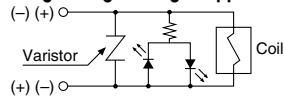

- Connect the standard type in accordance with the +, - polarity indication. (The non-polar type can be used with the connections made either way.)
- Since voltage specifications other than standard 24 V and 12 VDC do not have diodes for polarity protection, be careful not to make errors in the polarity.
- Please use caution regarding the allowable voltage fluctuation because there is about a 1 volt drop for a valve with polarity protection. (For details, refer to the solenoid specifications for the individual valve.)
- When wiring is done at the factory, positive (+) is red and negative (-) is black.

With power saving circuit

Power consumption is decreased by 1/4 by reducing the wattage required to hold the valve in an energised state. (Effective energising time is over 62 ms at 24 VDC.)

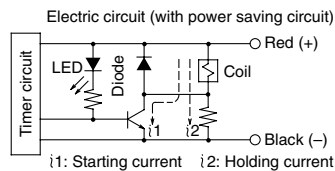

Operating Principle

With the above circuit, the current consumption when holding is reduced to save energy. Please refer to the electric wave data to the right.

- Please be careful not to reverse the polarity, since a diode to prevent the reversed current is not provided for the power saving circuit.
- Please use caution regarding the allowable voltage fluctuation because there is about a 0.5 volt drop due to the transistor. (For details, refer to the solenoid specifications for the individual valve.)

(In the case of SYJ□□□□T, the electric wave form of energy saving type)

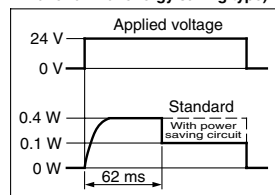

DIN Terminal

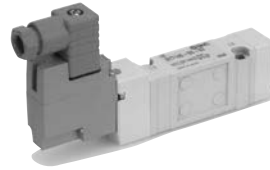

DIN terminal has no polarity.

With surge voltage suppressor (DS)

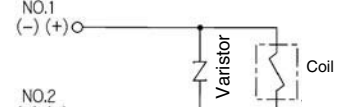

With light/surge voltage suppressor (DZ)

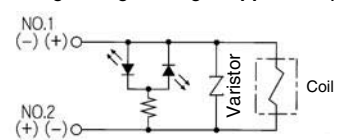

M8 Connector

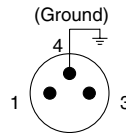

Solenoid valve side pin wiring diagram (For W type)

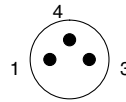

Solenoid valve side pin wiring diagram (For WA type)

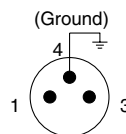

Solenoid valve side pin wiring diagram (For W type)

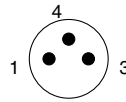

Solenoid valve side pin wiring diagram (For WA type)

Standard type (with polarity)

With light/surge voltage suppressor (□S)

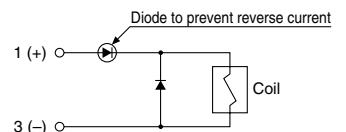

With light/surge voltage suppressor (□Z)

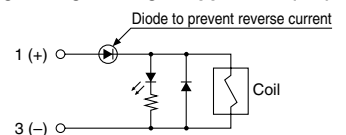

Non-polar type

With surge voltage suppressor (□R)

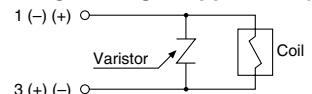

With light/surge voltage suppressor (□U)

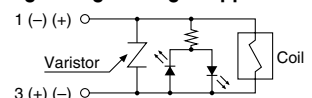

- In the case of standard type, connect + to 1 and - to 3 for W type, and connect + to 4 and - to 3 for WA type, according to the polarity.

- For DC voltages other than 12 V and 24 V, incorrect wiring will cause damage to the surge suppressor circuit.

- Please use caution regarding the allowable voltage fluctuation because there is about a 1 volt drop for a valve with polarity protection. (For details, refer to the solenoid specifications for the individual valve.)



Series SYJ300/500/700 Specific Product Precautions 4

Be sure to read before handling.

Refer to back page 1 through to 4 for Safety Instructions and Common Precautions.

Surge Voltage Suppressor

<For AC>

(There is no "S" type because the generation of surge voltage is prevented by a rectifier.)

Caution

DIN Terminal

With light (DZ)

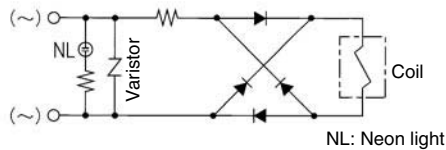

Note) Surge voltage suppressor of varistor has residual voltage corresponding to the protective element and rated voltage; therefore, protect the controller side from the surge. The residual voltage of the diode is approximately 1 V.

How to Use DIN Terminal

Caution

Connection

1. Loosen the holding screw and pull the connector out of the solenoid valve terminal block.
2. After removing the holding screw, insert a flat head screwdriver, etc. into the notch on the bottom of the terminal block and pry it open, separating the terminal block and the housing.
3. Loosen the terminal screws (slotted screws) on the terminal block, insert the cores of the lead wires into the terminals according to the connection method, and fasten them securely with the terminal screws.
4. Secure the cord by fastening the ground nut.

Caution

When making connections, take note that using other than the supported size ($\varnothing 3.5$ to $\varnothing 7$) heavy duty cord will not satisfy IP65 (enclosure) standards. Also, be sure to tighten the ground nut and holding screw within their specified torque ranges.

Changing the entry direction

After separating the terminal block and housing, the cord entry can be changed by attaching the housing in the desired direction (4 directions at 90° intervals).

* When equipped with a light, be careful not to damage the light with the cord's lead wires.

How to Use DIN Terminal

Caution

Precautions

Plug in and pull out the connector vertically without tilting to one side.

Compatible cable

Cord O.D.: $\varnothing 3.5$ to $\varnothing 7$

(Reference) 0.5 mm^2 , 2-core or 3-core, equivalent to JIS C 3306

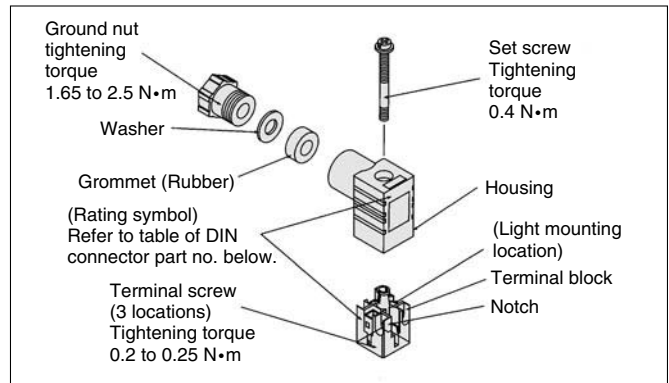

Solenoid Valve Mounting

Caution

Mount it so that there is no slippage or deformation in gaskets, and tighten with the tightening torque as shown below.

Model	Thread size	Tightening torque
SYJ300	M1.7	0.12 N·m
SYJ500	M2.5	0.45 N·m
SYJ700	M3	0.8 N·m

DIN Connector Part No.

Caution

Without light		SY100-61-1
With light		
Rated voltage	Voltage symbol	Model no.
24 VDC	24 V	SY100-61-3-05
12 VDC	12 V	SY100-61-3-06
100 VAC	100 V	SY100-61-2-01
200 VAC	200 V	SY100-61-2-02
110 VAC	110 V	SY100-61-2-03
220 VAC	220 V	SY100-61-2-04

Circuit Diagram with Light

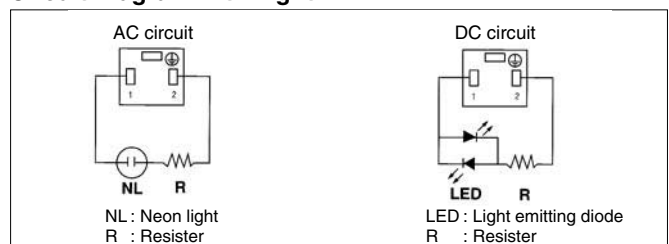

Note) Refer to page 57 for DIN connector (Y) conforming to EN-175301-803C (former DIN 43650C).



Series SYJ300/500/700

Specific Product Precautions 5

Be sure to read before handling.

Refer to back page 1 through to 4 for Safety Instructions and Common Precautions.

Connector Assembly with Cover

⚠ Caution

Connector assembly with dust proof protective cover.

- Effective to prevention of short circuit failure due to the entry of foreign matter into the connector.
- Chloroprene rubber for electrical use, which provides outstanding weather resistance and electrical insulation, is used for the cover material. However, do not allow contact with cutting oil, etc.
- Simple and unencumbered appearance by adopting round-shaped cord.

How to Order

SY100-68-A 

• Lead wire length

-	300 mm
6	600 mm
10	1000 mm
15	1500 mm
20	2000 mm
25	2500 mm
30	3000 mm
50	5000 mm

Connector Assembly with Cover: Dimensions

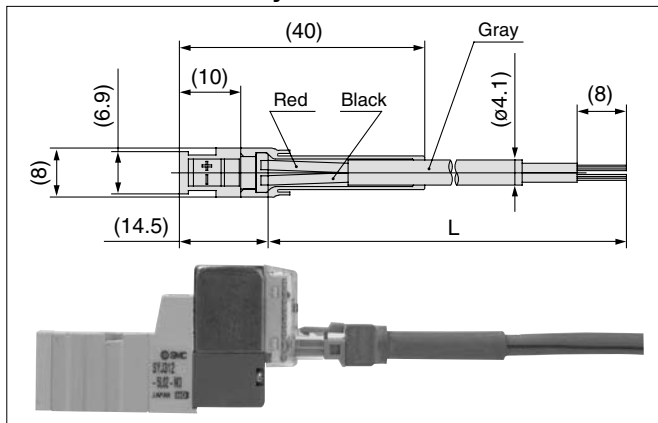

How to Order

Enter the part number for a plug connector solenoid valve without connector together with the part number for a connector assembly with cover.

Ex. 1) Lead wire length of 2000 mm
SYJ312-5LOZ-M3-Q
SY100-68-A-20

Ex. 2) Lead wire length of 300 mm (standard)
SYJ312-5LPZ-M3-Q

 Symbol for connector assembly with cover

* In this case, the part number for the connector assembly with cover is not required.

M8 Connector

⚠ Caution

1. M8 connector types have an IP65 (enclosure) rating, offering protection from dust and water. However please note: these products are not intended for use in water. Select a SMC connector cable (V100-49-1-□) or a FA sensor type connector, with M8 threaded 3 pin specifications conforming to Nippon Electric Control Equipment Association Standard, NECA4202 (IEC60947-5-2). Make sure the connector O.D. is 10.5 mm or less when used with the Series SYJ300 manifold. If more than 10.5 mm, it cannot be mounted due to the size.
2. Do not use a tool to mount the connector, as this may cause damage. Only tighten by hand. (0.4 to 0.6 Nm)
3. The excessive stress on the cable connector will not be able to satisfy the IP65 rating. Please use caution and do not apply a stress of 30 N or greater.

⚠ Caution

Failure to meet IP65 performance may result if using alternative connectors than those shown above, or when insufficiently tightened.

- Connector cable mounting

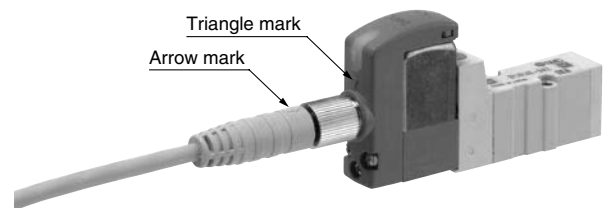

Note) Connector cable should be mounted in the correct direction. Make sure that the arrow symbol on the connector is facing the triangle symbol on the valve when using SMC connector cable (V100-49-1-□). Be careful not to squeeze it in the wrong direction, as problems such as pin damage may occur.



Series SYJ300/500/700

Specific Product Precautions 6

Be sure to read before handling.

Refer to back page 1 through to 4 for Safety Instructions and Common Precautions.

M8 Connector

■ Connector cable

- M8 connector cable for M8 can be ordered as follows:

How to Order

1. To order solenoid valve and connector cable at the same time.
(Connector cable will be included in the shipment of the solenoid valve.)

SYJ³₅⁷□□-□□□□-□□-□

• Electrical entry

W1, WA1: Cable length 300 mm

W2, WA2: Cable length 500 mm

W3, WA3: Cable length 1000 mm

W4, WA4: Cable length 2000 mm

W7, WA7: Cable length 5000 mm

Ex. 1) Cable length: 300 mm

SYJ312-5W1ZE-M3-Q

↳ Symbol for electrical entry

2. To order connector cable only

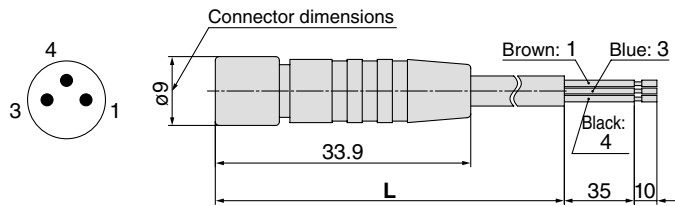

Cable length (L)	No.
300 mm	V100-49-1-1
500 mm	V100-49-1-2
1000 mm	V100-49-1-3
2000 mm	V100-49-1-4
5000 mm	V100-49-1-7

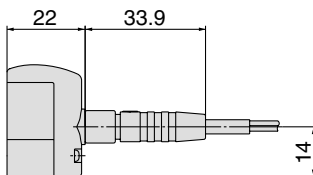

How to Measure the Flow Rate

⚠ Caution

Refer to pages 69 and 70: How to measure the flow rate.

Replacement of Pilot Valve

⚠ Caution

Pilot valves in this series are improved to provide excellent energy saving results. However following this improvement, these new valves are no longer compatible with the conventional pilot valve used at the interface. Consult with SMC when you need to exchange these pilot valves, in the case of manual override (marked in orange) of the adapter plate.

New type

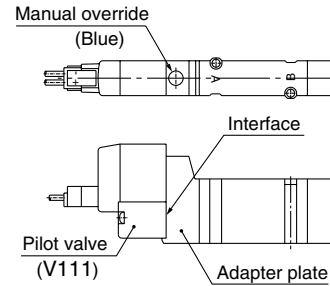

Conventional type

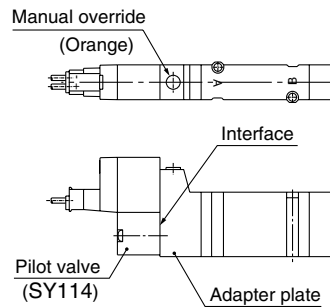



EUROPEAN SUBSIDIARIES:



Austria

SMC Pneumatik GmbH (Austria).
Girakstrasse 8, A-2100 Korneuburg
Phone: +43 2262-62280, Fax: +43 2262-62285
E-mail: office@smc.at
<http://www.smc.at>



France

SMC Pneumatique, S.A.
1, Boulevard de Strasbourg, Parc Gustave Eiffel
Bussy Saint Georges F-77607 Marne La Vallée Cedex 3
Phone: +33 (0)1-6476 1000, Fax: +33 (0)1-6476 1010
E-mail: contact@smc-france.fr
<http://www.smc-france.fr>



Netherlands

SMC Pneumatics BV
De Ruyterkade 120, NL-1011 AB Amsterdam
Phone: +31 (0)20-5318888, Fax: +31 (0)20-5318880
E-mail: info@smcpneumatics.nl
<http://www.smcpneumatics.nl>



Spain

SMC España, S.A.
Zuazobidea 14, 01015 Vitoria
Phone: +34 945-184 100, Fax: +34 945-184 124
E-mail: post@smc.smces.es
<http://www.smces.es>



Belgium

SMC Pneumatics N.V./S.A.
Nijverheidsstraat 20, B-2160 Wommelgem
Phone: +32 (0)3-355-1464, Fax: +32 (0)3-355-1466
E-mail: post@smcpneumatics.be
<http://www.smcpneumatics.be>



Germany

SMC Pneumatik GmbH
Boschring 13-15, D-63329 Egelsbach
Phone: +49 (0)6103-4020, Fax: +49 (0)6103-402139
E-mail: info@smc-pneumatik.de
<http://www.smc-pneumatik.de>



Norway

SMC Pneumatics Norway A/S
Vollsveien 13 C, Granfos Næringspark N-1366 Lysaker
Tel: +47 67 12 90 20, Fax: +47 67 12 90 21
E-mail: post@smc-norge.no
<http://www.smc-norge.no>



Sweden

SMC Pneumatics Sweden AB
Ekhagsvägen 29-31, S-141 71 Huddinge
Phone: +46 (0)8-603 12 00, Fax: +46 (0)8-603 12 90
E-mail: post@smcpneumatics.se
<http://www.smc.nu>



Bulgaria

SMC Industrial Automation Bulgaria EOOD
16 Kliment Ohridski Blvd., fl.13 BG-1756 Sofia
Phone: +359 2 9744492, Fax: +359 2 9744519
E-mail: office@smc.bg
<http://www.smc.bg>



Greece

SMC Hellas EPE
Anagenniseos 7-9 - P.C. 14342, N. Philadelphia, Athens
Phone: +30-210-2717265, Fax: +30-210-2717766
E-mail: sales@smchellas.gr
<http://www.smchellas.gr>



Poland

SMC Industrial Automation Polska Sp.z.o.o.
ul. Poloneza 89, PL-02-826 Warszawa,
Phone: +48 22 211 9600, Fax: +48 22 211 9617
E-mail: office@smc.pl
<http://www.smc.pl>



Switzerland

SMC Pneumatik AG
Dorfstrasse 7, CH-8484 Weisslingen
Phone: +41 (0)52-396-3131, Fax: +41 (0)52-396-3191
E-mail: info@smc.ch
<http://www.smc.ch>



Croatia

SMC Industrijska automatika d.o.o.
Cromerec 12, 10000 ZAGREB
Phone: +385 1 377 66 74, Fax: +385 1 377 66 74
E-mail: office@smc.hr
<http://www.smc.hr>



Hungary

SMC Hungary Ipari Automatizálási Kft.
Budafoki út 107-113, H-1117 Budapest
Phone: +36 1 371 1343, Fax: +36 1 371 1344
E-mail: office@smc.hu
<http://www.smc.hu>



Portugal

SMC Sucursal Portugal, S.A.
Rua de Engº Ferreira Dias 452, 4100-246 Porto
Phone: +351 22-610-89-22, Fax: +351 22-610-89-36
E-mail: postpt@smc.smces.es
<http://www.smces.es>



Turkey

Entek Pnömatik San. ve Tic Ltd. Sti.
Perpa Tic. Merkezi Kat: 11 No: 1625, TR-80270 Okmeydanı Istanbul
Phone: +90 (0)212-221-1512, Fax: +90 (0)212-221-1519
E-mail: smc-entek@entek.com.tr
<http://www.entek.com.tr>



Czech Republic

SMC Industrial Automation CZ s.r.o.
Hudcova 78a, CZ-61200 Brno
Phone: +420 5 414 24611, Fax: +420 5 412 18034
E-mail: office@smc.cz
<http://www.smc.cz>



Ireland

SMC Pneumatics (Ireland) Ltd.
2002 Citywest Business Campus, Naas Road, Saggart, Co. Dublin
Phone: +353 (0)1-403 9000, Fax: +353 (0)1-464-0500
E-mail: sales@smcpneumatics.ie
<http://www.smcpneumatics.ie>



Romania

SMC Romania srl
Str Frunzei 29, Sector 2, Bucharest
Phone: +40 213205111, Fax: +40 213261489
E-mail: smcromania@smcromania.ro
<http://www.smcromania.ro>



UK

SMC Pneumatics (UK) Ltd
Vincent Avenue, Crownhill, Milton Keynes, MK8 0AN
Phone: +44 (0)800 1382930 Fax: +44 (0)1908-555064
E-mail: sales@smcpneumatics.co.uk
<http://www.smcpneumatics.co.uk>



Denmark

SMC Pneumatik A/S
Knudsminde 4B, DK-8300 Odder
Phone: +45 70252900, Fax: +45 70252901
E-mail: smc@smc-pneumatik.dk
<http://www.smcdk.com>



Italy

SMC Italia S.p.A
Via Garibaldi 62, I-20061 Carugate, (Milano)
Phone: +39 (0)2-92711, Fax: +39 (0)2-9271365
E-mail: mailbox@smcitalia.it
<http://www.smcitalia.it>



Russia

SMC Pneumatik LLC.
4B Sverdlovskaja nab, St. Petersburg 195009
Phone: +7 812 718 5445, Fax: +7 812 718 5449
E-mail: info@smc-pneumatik.ru
<http://www.smc-pneumatik.ru>



Estonia

SMC Pneumatics Estonia OÜ
Laki 12, 106 21 Tallinn
Phone: +372 6510370, Fax: +372 65110371
E-mail: smc@smcpneumatics.ee
<http://www.smcpneumatics.ee>



Latvia

SMC Pneumatics Latvia SIA
Smerla 1-705, Riga LV-1006
Phone: +371 781-77-00, Fax: +371 781-77-01
E-mail: info@smclv.lv
<http://www.smclv.lv>



Slovakia

SMC Priemyselná Automatizácia, s.r.o.
Námestie Matina Benku 10, SK-81107 Bratislava
Phone: +421 2 444 56725, Fax: +421 2 444 56028
E-mail: office@smc.sk
<http://www.smc.sk>



Finland

SMC Pneumatics Finland Oy
PL72, Tiistinniityntie 4, SF-02231 ESPOO
Phone: +358 207 513513, Fax: +358 207 513595
E-mail: smcfi@smc.fi
<http://www.smc.fi>



Lithuania

SMC Pneumatics Lietuva, UAB
Oslo g.1, LT-04123 Vilnius
Phone: +370 5 264 81 26, Fax: +370 5 264 81 26



Slovenia

SMC industrijska Avtomatika d.o.o.
Mirnska cesta 7, SLO-8210 Trebnje
Phone: +386 7 3885412 Fax: +386 7 3885435
E-mail: office@smc.si
<http://www.smc.si>



OTHER SUBSIDIARIES WORLDWIDE:

ARGENTINA, AUSTRALIA, BOLIVIA, BRASIL, CANADA, CHILE,
CHINA, HONG KONG, INDIA, INDONESIA, MALAYSIA, MEXICO,
NEW ZEALAND, PHILIPPINES, SINGAPORE, SOUTH KOREA,
TAIWAN, THAILAND, USA, VENEZUELA

<http://www.smc.eu>
<http://www.smcworld.com>